

Stress-strain relation of integral type for deformation of brass along strain trajectories consisting of three normal straight branches

**Y. OHASHI (NAGOYA) M. TOKUDA (TSU CITY) T. MIYAKE, Y. KURITA
and T. SUZUKI (NAGOYA)**

A METHOD to formulate a stress-strain relation of the integral type for plastic deformations of metals is set up according to the concept of the intrinsic time scale proposed by Valanis in his endochronic theory. Since Ilyushin's postulate of isotropy concerning the strain trajectory has been ascertained to hold in the vector space corresponding to the strain deviator after the effect of the third invariant has been modified, the method may be applied to strain trajectories of the same geometry independently of their orientation in the vector space. The propriety of this method is confirmed by applying it to the deformation of brass along trajectories consisting of three normal straight branches, as an example of complex history effects. Reasonable estimation of Ilyushin's trace of delay is discussed also in this example.

Opracowano metodę formułowania zależności całkowitej pomiędzy odkształceniem i naprężeniem dla plastycznej deformacji metali na podstawie koncepcji skali czasu wewnętrznego proponowanej przez Valanisa w jego teorii endochronicznej. Ponieważ udowodniono, że postulat izotropii Iliuszina dotyczący trajektorii odkształcenia jest spełniony w przestrzeni wektorowej odpowiadającej dewiatorowi odkształcenia pod warunkiem modyfikacji trzeciego niezmiennika, więc metoda ta może być zastosowana do trajektorii odkształceń o tej samej geometrii niezależnie od ich orientacji w przestrzeni wektorowej. Poprawność metody została potwierdzona przez zastosowanie jej do problemu odkształcenia mosiądzu wzdłuż trajektorii złożonych z trzech prostopadłych prostych gałęzi, jako przykładu efektu skomplikowanej historii. Jako przykład przedyskutowano również oszacowanie śladu opóźnienia Iliuszina.

Разработан метод формулировки интегральной зависимости между деформацией и напряжением для пластической деформации металлов на основе понятия масштаба внутреннего времени, предложенного Валинисом в его эндохронической теории. Т. к. доказано, что постулат изотропии Илюшина, касающийся траектории деформации, удовлетворен в векторном пространстве, отвечающем косому тензору напряжений при условии модификации третьего инварианта, значит этот метод может быть применен к траектории деформаций, с той самой геометрией, независимо от их ориентировки в векторном пространстве. Правильность метода подтверждена путем применения его к проблеме деформации латуни вдоль траекторий, состоящих из трех перпендикулярных прямых ветвей, как пример эффекта сложной истории. В характере примера обсуждена тоже оценка следа запаздывания Илюшина.

1. Introduction

THE DEFORMATION behaviour of metals varies according to the change of their microstructure due to plastic deformation. The history dependence always appears in the plastic deformation of metallic materials. When the plastic behaviour is expressed by means of the stress-strain relation, the history dependence in this relation may be estimated by using the deformation history in the shape of a tensorial curve in the space of the strain tensor.

The stress-strain relation varies in accordance with the shape of the tensorial curve whenever the history dependence appears in the deformation behaviour, and thus the relation cannot be realized in the form of a definite function without assigning a definite geometry of the curve. As a mathematical expression of deformation history, ILYUSHIN [1] used a strain trajectory in the vector space of the strain deviator corresponding to the space of the strain tensor instead of the above mentioned tensorial curve. Relating to this strain trajectory, he proposed a postulate which states that the effect of deformation history of materials on their stress-strain relation depends only on the geometry of the strain trajectory independently of the orientation (rotation and mirror transformation) of the trajectory in the vector space. He called this postulate the "postulate of isotropy" [1].

The isotropic tensor space cannot always be transformed into the isotropic vector space because both the vector space and the corresponding tensor space are not necessarily equivalent. Therefore, the postulate of isotropy does not always hold with sufficient accuracy on the basis of the experimental results obtained for real materials. However, if modified amounts are taken by considering the distribution of the third invariant of the deviatoric tensor in the vector space [2-5], the postulate can be ascertained to hold on the basis of real materials.

By using the vector space, a geometrical concept of deformation history may be secured easily by drawing curves. Moreover, the postulate of isotropy which states that deformation history depends only on the geometry of the curve (sequence of applications and magnitudes of strain components and their variations in the history) independently of the orientation of the curve in the vector space (kinds of strain components) has a significant meaning in systematizing the varieties of complicated deformation histories.

When the curve expressing deformation history is assigned, the stress state at an arbitrary instant in the deformation process may be expressed by a stress vector in a local vector space of the stress deviator established at the corresponding point on the curve.

If two points closely adjacent are taken arbitrarily on the curve, the stress increment between these two points depends on the corresponding strain increment what can be expressed in the following form;

$$(1.1) \quad d\sigma = \mathbf{K}' de.$$

Here \mathbf{K}' plays the role of the influence coefficient of the strain increment to the stress increment. If the deformation property does not vary completely, \mathbf{K}' may be expressed in terms of a matrix having constant elements and is independent of the geometry of the curve. This situation corresponds to the elastic deformation. When the history dependence appears, the influence coefficient varies at each point on the curve according to its geometry. The coefficient of de at the preceding point contributing to the stress increment $d\sigma$ at a point considered on the curve may be a function of arc length together with the geometric parameters (curvature, torsion and others) of the curve. Accordingly, the stress state at a certain point (s) on the curve may be expressed by an integral form

$$(1.2) \quad \sigma(s) = \int_0^s \mathbf{K}(\kappa_i; s, s') de(s'), \quad 0 \leq s' \leq s$$

of the stress increment taken at every preceding point (s'), where s and s' denote the arc length of the curve $s = \sqrt{(2/3)} de_{ij} de_{ij}$ up to the corresponding points, and $\kappa_i(s')$ are the geometric parameters. Ilyushin proposed other integral forms,

$$(1.3) \quad \sigma(s) = \int_{s-h}^s \mathbf{K}(\kappa_i; s, s') de(s'), \quad s-h \leq s' \leq s,$$

restricting the range of integration to a definite arc length h ($s-h \leq s' \leq s$) preceding the point (s) instead of $0 \leq s' \leq s$, by taking into account the fading memory which appears in real materials. The arc length h is called "trace of delay". This hypothesis is called ILYUSHIN'S "principle of delay" [1]. According to this principle, the expression of the history effect may be remarkably simplified as the effect can be considered by taking account of the geometry of the curve only in a finite range preceding the point considered.

In the linear viscoelastic theory, for the stress-strain relation of history-dependent materials, the stress components at a certain instant t in the real time scale during the deformation process have been expressed in the following form:

$$(1.4) \quad \sigma_{ij}(t) = \int_0^t K_{ijmn}(t, \tau) d\varepsilon_{mn}(\tau), \quad 0 \leq \tau \leq t.$$

In this form, since the stress-strain relation is expressed in terms of real time as a parameter, the influence coefficient may be understood as a function of real time. That is, the deformation property may be understood to vary according to real time. However, since the deformation property of real materials depends not on time but essentially on deformation history, the concept expressed in the form (1.4) is not always accurate because it may express definite deformation phenomena only when a certain relation between deformation history and time is given for the influence coefficient.

In the linear viscoelastic theory, the form [6]

$$(1.5) \quad \sigma_{ij}(t) = \int_0^t K_{ijmn}(t-\tau) d\varepsilon_{mn}(\tau), \quad 0 \leq \tau \leq t$$

is often used as a special case of Eq. (1.4) together with

$$(1.6) \quad K_{ijmn}(t-\tau) = \mu_{ijmn} e^{-\lambda(t-\tau)}$$

for convenience of calculation as well as for the consideration of fading memory. Such a coefficient of the difference type is a fairly strong limitation since it is effective only for the deformation in which the influence function may always be described using Eq. (1.6) for the arbitrary instant t .

Recently, VALANIS [7] proposed an "endochronic theory" for materials with memory depending on deformation history. According to this theory, the relation between the stress deviator S_{ij} and the strain deviator e_{ij} is expressed in the following form:

$$(1.7) \quad S_{ij} = 2 \int_0^z K(z, z') \frac{de_{ij}}{dz'} dz' = 2 \int_0^{\xi} K\{z(\xi), z'(\xi)\} \frac{de_{ij}}{d\xi'} d\xi'$$

with the use of an intrinsic time scale z , where an intrinsic time measure ζ is defined as

$$(1.8) \quad d\zeta^2 = k^2 de_{ij} de_{ij}, \quad (k > 0: \text{ material parameter}).$$

The intrinsic time scale z , which expresses the sequence of variations of the deformation behaviour of materials and does not necessarily correspond to real time, is defined as a monotonously increasing positive function of the intrinsic time measure ζ as follows:

$$(1.9) \quad dz(\zeta) = d\zeta/f(\zeta) \quad \text{or} \quad z(\zeta) = \int_0^\zeta \frac{d\zeta'}{f(\zeta')}, \quad dz/d\zeta > 0.$$

It may be found from Eq. (1.8) that the intrinsic time measure ζ is a certain parameter expressing the deformation behaviour in relation to the deformation history of materials, and thus the measure is related with the form and intensity of deformation. As follows from Eq. (1.9), if a converted time scale reflecting the history dependence is used for establishing a stress-strain relation (taking into account the variation of the deformation property since this variation due to history may be reflected only in the function $f(\zeta)$), the formula (1.7) having the same form as Eq. (1.4) may be expressed in an analogous form as Eq. (1.5) together with Eq. (1.6). The corresponding influence coefficient of the difference type $K\{z(\zeta) - z(\zeta')\}$ is free from the above mentioned limitation for each value of $z(\zeta)$ according to which Eqs. (1.5) and (1.6) founded on the simple concept have been restricted. This is so because the value $z(\zeta) - z(\zeta')$ is not constant but is always a function of the corresponding value of ζ . Consequently, the stress-strain relation may be formulated reasonably for plastic behaviour under arbitrary deformation history if Valanis' endochronic theory is used together with Ilyushin's postulate of isotropy and principle of delay.

As an example of the application of his theory, VALANIS calculated a plastic deformation under tension after torsion [7]. He expressed Eq. (1.8) in the form $d\zeta^2 = k_1 d\varepsilon^2 + k_2 d\eta^2$, used a linear function $f(\zeta) = 1 + \beta\zeta$ of ζ , and established a stress-strain relation for tension after torsion, by using the parameter $\zeta_0 = k_2 \eta_0$ showing torsional pre-strain as well as a cross-hardening parameter β . Moreover, in the tensile deformation the relation $\zeta = \zeta_0 + k_1 \varepsilon$ or $d\zeta = k_1 d\varepsilon$ is assumed, and a new parameter $\beta_1 = k_1 \beta$ is determined under the assumption that the stress-strain curve under uniaxial tension, starting at the state where torsional prestrain has vanished after pre-torsion, would tend to a linear form

$$(1.10) \quad \sigma = \frac{E_0}{\beta_1 n} (1 + \beta_1 \varepsilon)$$

for a sufficiently large value of the tensile strain ε .

However, his method as quoted above was not found to be sufficient to approximate with high accuracy the experimental results of plastic deformation of brass under a severe history effect mentioned in the previous paper [8]. There, thin-walled tubular specimens are deformed along strain trajectories of three straight branches intersecting normally in the

vector space of the strain deviator under combined load of torsion and axial force. This may be attributed to the fact that the influence coefficient and the intrinsic time scale z were not found in suitable forms to reflect reasonably a severe history effect.

In the present paper a method is proposed to formulate the experimental results of plastic deformation of brass having a severe history effect in the form of the integral type, by selecting the influence coefficient and the intrinsic time scale z so as to be able to reflect reasonably the history effect.

2. Fundamental equations

The history of the strain deviator appearing in the thin-walled tubular specimen under torsion and axial force may be described as curves showing the strain trajectory in a vector plane of the strain deviator ($e_1 = e_{11}$, $e_3 = 2e_{12}/\sqrt{3}$), where e_{11} and e_{12} denote the axial and shear components of the strain deviator calculated from the experimental results of the thin-walled tubular specimen, and the indices 1 and 2 correspond to the axial and circumferential directions of the specimen, respectively. The states of the strain deviator and its increment at each point on the curve may be expressed by a strain vector $\mathbf{e} = e_{11}\mathbf{n}_1 + (2/\sqrt{3})e_{12}\mathbf{n}_2$ ($|\mathbf{e}|$ is equal to the effective strain ε_{eq}) and $d\mathbf{e} = de_{11}\mathbf{n}_1 + (2/\sqrt{3})de_{12}\mathbf{n}_2$, respectively. Moreover, the state of the stress deviator may be expressed by a stress vector $\boldsymbol{\sigma} = \sigma_{11}\mathbf{n}_1 + \sqrt{3}\sigma_{12}\mathbf{n}_2$ ($|\boldsymbol{\sigma}|$ is equal to the effective stress σ_{eq}) in a local vector space of the stress deviator ($S_{11} = (3/2)\sigma_{11} = (3/2)\sigma_1$, $S_{12} = \sigma_{12} = \sigma_3/\sqrt{3}$) where σ_{11} and σ_{12} denote the axial and shear stress components. These components appear in the specimen after modifying the effect of the third invariant in the vector space, as mentioned in the previous papers [2-5] in detail. \mathbf{n}_1 and \mathbf{n}_2 are the orthonormal base vector in the stress and the strain vector space in common.

By using the components mentioned above, the formula (1.2) is expanded into the following forms:

$$\sigma_{11} = \int_0^s K_{11}(s, s'; \kappa_i) de_{11} + \frac{2}{\sqrt{3}} \int_0^s K_{12}(s, s'; \kappa_i) de_{12}, \quad (2.1)$$

$$\sqrt{3} \sigma_{12} = \int_0^s K_{21}(s, s'; \kappa_i) de_{11} + \frac{2}{\sqrt{3}} \int_0^s K_{22}(s, s'; \kappa_i) de_{12},$$

where κ_i in the arguments of the influence functions in Eqs. (2.1) are the geometric parameters of the strain trajectory expressing the deformation history of materials quantitatively. If the history effect including the effect appearing in the case of zero-curvature is reflected in the functional relation $z(s)$ by putting $\zeta = s$, and the influence coefficients are expressed as $K_{ij}\{z(s), z(s')\}$, the above formula (2.1) may be transformed as follows:

$$\sigma_{11} = \frac{3}{2} S_{11} = \int_0^s K_{11}\{z(s), z(s')\} \frac{de_{11}}{ds'} ds' + \frac{2}{\sqrt{3}} \int_0^s K_{12}\{z(s), z(s')\} \frac{de_{12}}{ds'} ds', \quad (2.2)$$

$$\sqrt{3} \sigma_{12} = \sqrt{3} S_{12} = \int_0^s K_{21}\{z(s), z(s')\} \frac{de_{11}}{ds'} ds' + \frac{2}{\sqrt{3}} \int_0^s K_{22}\{z(s), z(s')\} \frac{de_{12}}{ds'} ds'.$$

Valanis defined the intrinsic time measure ζ in relation to the features of strain state and the response of the material to that state in the material parameter k in Eq. (1.8). He also determined the influence coefficient in the form of the scalar function due to the proportional deformation by assuming a simple scalar relation between the intrinsic time measure and the intrinsic time scale.

However, his method is not suitable to formulate reasonably deformation behaviour along the strain trajectory with a corner. On the other hand, in order to reflect the experimental fact in which the response of materials is affected essentially by the existence of corners, the influence coefficients and the functions $z(s)$ and $z(s')$ in Eqs. (2.2) are assumed to have different characters before and after the corner.

In the following, the experimental results [8] along the strain trajectories consisting of three straight branches intersecting normally, will be formulated by using Eqs. (2.2). As shown in Fig. 1, the experimental results have been obtained along the strain trajectory

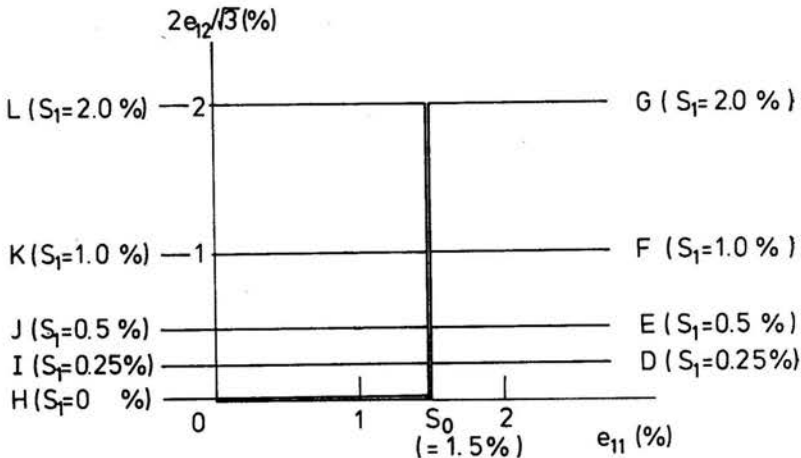

FIG. 1. Strain trajectories consisting of three normal straight branches.

consisting of the first branch ($de_{11} > 0$, $de_{12} = 0$, $0 \leq s \leq s_0$), the second branch ($de_{11} = 0$, $de_{12} > 0$, $s_0 \leq s \leq s_1$) and the third branch ($de_{11} \neq 0$, $de_{12} = 0$, $s_1 \leq s$), and thus the stress-strain relation will be formulated in relation to each branch.

2.1. First branch ($0 \leq s \leq s_0$)

Since $de_{11} > 0$, $de_{12} = 0$ and there is no shear stress ($\sigma_{12} = 0$) in this branch, the stress-strain relation may be established from Eqs. (2.2) by using K_a and $z_a(s)$ as the influence coefficient K_{11} , and the intrinsic time scale $z(s)$ as follows:

$$(2.3) \quad S_{11}(s) = \frac{2}{3} \int_0^s K_a \{z_a(s), z_a(s')\} \frac{de_{11}}{ds'} ds'$$

If a function of the difference type

$$K_a \{z_a(s), z_a(s')\} = \mu_a e^{-\{z_a(s) - z_a(s')\}}, \quad \mu_a - \text{const},$$

is used as the influence coefficient, then the contribution of the strain increment $d\epsilon$ at the preceding instant of the intrinsic time scale $z_a(s')$ to the stress increment $d\sigma$ at the instant $z_a(s)$ decreases from a constant amount $d\sigma = \mu_a d\epsilon$ exponentially in relation to the intrinsic time interval between these two instants, and Eq. (2.3) is described as follows:

$$(2.4) \quad S_{11}(s) = \frac{2}{3} \mu_a e^{-z_a(s)} \int_0^s e^{z_a(s')} \frac{de_{11}}{ds'} ds', \quad 0 \leq s' \leq s.$$

Since the variations of the deformation property are reflected in the functions $z_a(s)$ and $z_a(s')$, the coefficient of the difference type may be applied to arbitrary values of s and s' , and the above equation can formulate the experimental results with high accuracy.

2.2. Second branch ($s_0 \leq s \leq s_0 + s_1$)

When a point under consideration (s) lies on the second branch, the contribution of $d\epsilon$ at the preceding point (s') to the stress increment $d\sigma$ at the point (s) is quite different from that in the previous Sect. 2.1. For example, $d\epsilon (de_{11} > 0, de_{12} = 0)$ on the first branch changes suddenly into $d\epsilon (de_{11} = 0, de_{12} > 0)$ at the corner point $s = s_0$, while $|d\epsilon|/dt (= s)$ is kept constant along the trajectory, and S_{11} decreases quickly at first and slowly afterwards along the second branch. This trend may be attributed to the relaxation of S_{11} due to the sudden vanishing of de_{12} and a kind of instability of microstructure of materials at the corner $s_0 = e_{11}$. The instability may correspond to a release of dislocations which have piled up during the deformation process along the first branch by a disturbance de_{12} applied after the corner in another direction (release of a locked potential energy) [5]. By taking into account these effects, the influence coefficient on the second branch is distinguished as K_b which is different from K_a on the first branch. Moreover, for the same reasons the intrinsic time scale should also be different according to whether the preceding point (s') lies on the first or second branch. Therefore the influence coefficient at the point (s) on the second branch may be selected as

$$(2.5) \quad \begin{aligned} K_b \{z_{b\alpha}(s), z_{b\alpha}(s')\} &= \mu_b e^{-(z_{b\alpha}(s) - z_{b\alpha}(s'))}, \\ &\text{for } z(s_0) \leq z(s) \leq z(s_0 + s_1), \quad z(0) \leq z(s') \leq z(s_0), \\ K_b \{z_{b\beta}(s), z_{b\beta}(s')\} &= \mu_b e^{-(z_{b\beta}(s) - z_{b\beta}(s'))}, \\ &\text{for } z(s_0) \leq z(s) \leq z(s_0 + s_1), \quad z(s_0) \leq z(s') \leq z(s), \end{aligned}$$

and the stress-strain relations on the second branch are found from Eqs. (2.2) in the following form:

$$(2.6) \quad \begin{aligned} S_{11} &= \frac{2}{3} \int_0^s K_b \{z_{b\alpha}(s), z_{b\alpha}(s')\} \frac{de_{11}}{ds'} ds' = \frac{2}{3} \mu_b e^{-z_{b\alpha}(s)} \int_0^s e^{z_{b\alpha}(s')} \frac{de_{11}}{ds'} ds', \\ S_{12} &= \frac{2}{3} \int_{s_0}^s K_b \{z_{b\beta}(s), z_{b\beta}(s')\} \frac{de_{12}}{ds'} ds' = \frac{2}{3} \mu_b e^{-z_{b\beta}(s)} \int_{s_0}^s e^{z_{b\beta}(s')} \frac{de_{12}}{ds'} ds'. \end{aligned}$$

because $de_{12} = 0$ ($0 \leq s \leq s_0$) and $de_{11} = 0$ ($s_0 \leq s$). The influence coefficient K_{21} is equal to 0 because there is no shear stress S_{12} on the first branch, and K_{12} is neglected for little contribution of torsional strain to S_{11} on the second branch.

By using the expression $S_{11}(s_0) = \sigma_0$, σ_0 may be found from Eqs. (2.4) and the following relation is obtained from Eqs. (2.6)

$$\sigma_0 = \frac{2}{3} \mu_b e^{-z_{b\alpha}(s_0)} \int_0^{s_0} e^{z_{b\alpha}(s')} \frac{de_{11}}{ds'} ds'.$$

In this way we get

$$\int_0^{s_0} e^{z_{b\alpha}(s')} \frac{de_{11}}{ds'} ds' = \frac{3}{2\mu_b} \sigma_0 e^{z_{b\alpha}(s_0)}.$$

Consequently, the stress-strain relations on the second branch may be established as follows:

$$(2.7) \quad S_{11}(s) = \sigma_0 e^{-(z_{b\alpha}(s) - z_{b\alpha}(s_0))}, \quad S_{12}(s) = \mu_b e^{-z_{b\alpha}(s)} \int_{s_0}^s e^{z_{b\beta}(s')} \frac{de_{12}}{ds'} ds'.$$

2.3. Third branch ($s_0 + s_1 \leq s$)

Since the method for deriving the stress-strain relation is almost the same as those in the previous section, only the results are described without detailed derivations. On the third branch there are $de_{11} \neq 0$ and $de_{12} = 0$, and thus the stress-strain relation may be expressed as follows:

$$(2.8) \quad S_{11} = \frac{2}{3} \mu_c e^{-z_{c\alpha}(s)} \int_0^{s_0} e^{z_{c\alpha}(s')} \frac{de_{11}}{ds'} ds' + \frac{2}{3} \mu_c e^{-z_{c\gamma}(s)} \int_{s_0+s_1}^s e^{z_{c\gamma}(s')} \frac{de_{11}}{ds'} ds',$$

$$S_{12} = \frac{2}{3} \mu_c e^{-z_{c\beta}(s)} \int_{s_0}^{s_0+s_1} e^{z_{c\beta}(s')} \frac{de_{12}}{ds'} ds'.$$

If the values of S_{11} and S_{12} at the second corner $s = s_0 + s_1$ are denoted as σ_1 and τ_1 , the following relations are obtained from Eqs. (2.8):

$$\int_0^{s_0} e^{z_{c\alpha}(s')} \frac{de_{11}}{ds'} ds' = \frac{3}{2\mu_c} \sigma_1 e^{z_{c\alpha}(s_0+s_1)}, \quad \int_{s_0}^{s_0+s_1} e^{z_{c\beta}(s')} \frac{de_{12}}{ds'} ds' = \frac{3}{2\mu_c} \tau_1 e^{z_{c\beta}(s_0+s_1)}.$$

Consequently, the stress-strain relation on the third branch may be established as follows:

$$(2.9) \quad S_{11}(s) = \sigma_1 e^{-(z_{c\alpha}(s) - z_{c\alpha}(s_0+s_1))} + \frac{2}{3} \mu_c e^{-z_{c\gamma}(s)} \int_{s_0+s_1}^s e^{z_{c\gamma}(s')} \frac{de_{11}}{ds'} ds',$$

$$S_{12}(s) = \tau_1 e^{-(z_{c\beta}(s) - z_{c\beta}(s_0+s_1))}.$$

3. Determination of the intrinsic time scale $z(z_a, z_{b\alpha}, z_{b\beta}, z_{c\alpha}, z_{c\beta}, z_{c\gamma})$ and the coefficient $\mu(\mu_a, \mu_b, \mu_c)$

3.1. First branch (μ_a, z_a)

The following equation may be obtained by the Taylor expansion of Eqs. (2.4) in the vicinity of $s = 0$ and after disregarding the infinitesimal terms higher than the second order:

$$(3.1) \quad \Delta S_{11} = S_{11}(\Delta s) - S_{11}(0) = \frac{2}{3} \mu_a \frac{de_{11}}{ds} \Delta s = \frac{2}{3} \mu_a \Delta s, \quad (\Delta s = \Delta e_{11}).$$

By using Eq. (3.1), μ_a may be determined from the tensile stress response in the early stage of deformation.

The formula to find dz_a

$$(3.2) \quad dz_a = [(2/3)\mu_a de_{11} - dS_{11}]/S_{11}$$

may be obtained by transforming Eqs. (2.4) to a differential type. The values of $z_a(s)$ and $dz_a(s)$ may be calculated by using Eq. (3.2) from the experimental results obtained by uniaxial tension.

3.2. Second branch ($\mu_b, z_{b\alpha}, z_{b\beta}$)

The expression (2.7)₂ has the same form as Eqs. (2.4). Thus the following formula may be found in the same way as that for Eq. (3.1):

$$(3.3) \quad \Delta S_{12} = S_{12}(s_0 + \Delta s) - S_{12}(s_0) = \frac{2}{3} \mu_b \frac{de_{12}}{ds} \Delta s = \frac{2}{3} \mu_b \Delta s, \quad (\Delta s = \Delta e_{12}).$$

By using Eq. (3.3), μ_b may be found from the relation between shear stress and shear strain measured just after the corner. After transforming Eq. (2.7)₂ into a differential form, the following formula to find $dz_{b\beta}$ may be obtained:

$$(3.4) \quad dz_{b\beta} = [(2/3)\mu_b de_{12} - dS_{12}]/S_{12}.$$

In the same manner the formula

$$(3.5) \quad dz_{b\alpha} = -dS_{11}(s)/S_{11}(s)$$

may be found from Eq. (2.7)₁. By using these formulae the values of $z_{b\alpha}(s)$ and $z_{b\beta}(s)$ as well as $dz_{b\alpha}(s)$ and $dz_{b\beta}(s)$ may be found from the experimental results on the second branch.

3.3. Third branch ($s_0 + s_1 \leq s$)

By transferring the first term of the right hand side of Eq. (2.9)₁ to the other side, and indicating the left hand side as $X(s)$, the following formula may be obtained:

$$X(s) = S_{11}(s) - \sigma_1 e^{-(z_{c\alpha}(s) - z_{c\alpha}(s_0 + s_1))} = \frac{2}{3} \mu_c e^{-z_{c\gamma}(s)} \int_{s_0 + s_1}^s e^{z_{c\gamma}(s')} \frac{de_{11}}{ds'} ds'.$$

Then the Taylor expansion of $X(s)$ in the vicinity of $s = s_0 + s_1$ may derive

$$(3.6) \quad \Delta X = X(s_0 + s_1 + \Delta s) - X(s_0 + s_1) = S_{11}(s_0 + s_1 + \Delta s) - S_{11}(s_0 + s_1) \\ - \sigma_0 (e^{-\{z_{c\alpha}(s_0 + s_1 + \Delta s) - z_{c\alpha}(s_0 + s_1)\}} - 1) = \frac{2}{3} \mu_c \frac{de_{11}}{ds} \Delta s = \frac{2}{3} \mu_c \Delta e_{11}$$

after disregarding infinitesimal terms higher than the second order.

If the condition $z_{c\alpha}(s) = z_{c\gamma}(s)$ is assumed for simplicity, the formula

$$(3.7) \quad dz_{c\alpha} = dz_{c\gamma} = [(2/3)\mu_c de_{11} - dS_{11}]/S_{11}$$

is found from Eq. (2.9)₁. The formula

$$(3.8) \quad dz_{c\beta} = -dS_{12}(s)/S_{12}(s)$$

is also obtained from Eq. (2.9)₂.

By using Eqs. (3.6), (3.7) and (3.8), the values of μ_c , $z_{c\alpha}(s)$ ($=z_{c\gamma}(s)$) and $z_{c\beta}(s)$ as well as $dz_{c\alpha}(s)$ ($=dz_{c\gamma}(s)$) and $dz_{c\beta}(s)$ may be obtained from the experimental results along the third branch.

3.4. Values of μ and z found from the experimental results

The values of μ and z were determined by using the experimental results along the strain trajectories shown in Fig. 1. Since the stress-strain curves obtained from the experimental results did not tend to straight lines for large values of strain, the functional form $f(\zeta) = 1 + \beta\zeta$ used by VALANIS [7] was not suitable to reproduce them. On the other hand, the functional form $f(s) = a(s+c)^b$ was ascertained to be able to approximate every stress-strain curve with high accuracy. The corresponding values of a , b and c for each branch differ from each other. Since the amounts $s_0 = 1.5$ per cent ($= \text{const}$) as well as $s_1 = 0, 0.25, 0.5, 1.0$ and 2.0 per cent have been assigned, the values of a , b and c on the third branch should be functions of s_1 . Moreover, there are remarkable differences between the trends in the values of a , b , c and μ_c along the third branches of the group D through G , in which the magnitude of the stress vector continuously increases along the branch, and those along the third branches of the group H through L , in which the magnitude of the stress vector decreases in the early period of the third branch shown in Fig. 1. The differences correspond to the experimental results in which a strain-anisotropy analogous to the Bauschinger effect appears along the third branch in the latter group and decreases with an increase of s_1 . The functional relations of these characteristics relating to s_1 were obtained as follows:

$$z_{c\beta}: \quad a(s_1) = 5.26 \times 10^{-3} (1 - 0.6067e^{-89.45s_1}),$$

and for the group H through L

$$\mu_c(s_1)/3 = [1000(1 - e^{-314s_1}) + 1500] - 3.17 \times 10^5 s_1 e^{-250s_1},$$

$$z_{c\alpha} = z_{c\gamma}: \quad a(s_1) = (7.047e^{-s_1} + 7.013) \times 10^{-3},$$

$$b(s_1) = -0.4682s_1 + 2.611,$$

$$c(s_1) = -0.03414s_1 + 0.4297.$$

The values of μ and z obtained from the experimental results along the strain trajectories in the group D through G and the group H through L are summarized in the following tables (cf. Table 1 and Tables 2 and 3 from page 140).

Table 1. Values of μ and z for the first and second branches

$\mu(\text{kgf/mm}^2)$	z	a	b	c
$\mu_a = 14000$	z_a	3.38×10^{-3}	0.266	8.34×10^{-3}
$\mu_b = 7500$	$z_{b\alpha}$	5.26×10^{-3}	0	0
	$z_{b\beta}$	5.98×10^{-3}	0.246	7.03×10^{-3}

These values have been determined from the experimental results with $s_0 = 1.5$ percent. However, the values relating to the second and third branches may be functions of s_0 in general. On the other hand, it has been ascertained that the experimental results along the second branch for $s_0 = 1.17, 2.2$ and 3.2 per cent obtained in the previous experiment [9] are approximated with high accuracy by using the values shown in Table 1. This verifies the well-known property that the effect of pre-strain s_0 saturates for pre-strain of $s_0 \geq 1$ per cent.

4. Comparison of theoretical results with experimental ones

By using the characteristic values determined above, after the saturation of pre-strain s_0 , definite stress-strain relations may be realized for arbitrary deformations of brass along the above-mentioned strain trajectories for any amount of s_1 . Moreover, since the modi-

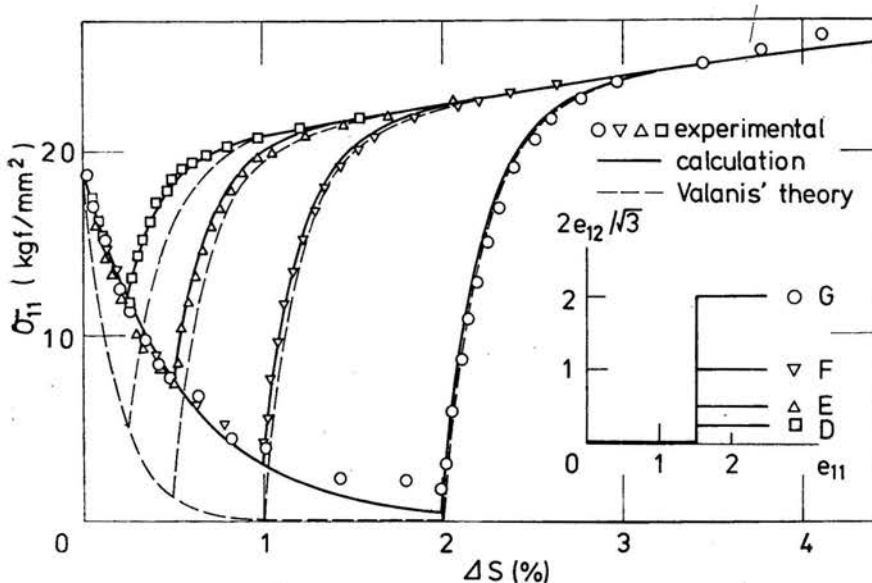

FIG. 2. Comparison of calculated results with experimental ones for group $D-G$ (σ_{11}).

fication of the effect of the third invariant has been conducted on the stress value, the stress-strain relation thus obtained may hold for any strain trajectory of the same geometry oriented in any direction in three-dimensional vector space (e_{11} , $(2/\sqrt{3})(e_{11}/2 + 2e_{22})$, $(2/\sqrt{3})e_{12}$) [5]. Corresponding stress values expected to be measured in the experiment may be obtained by restoring the effect of the third invariant from the stress values calculated by the above formulae. The stress-strain relations established above are compared with the corresponding experimental results by using the following figures.

The relation between the value $\sigma_{11} = (3/2)S_{11}$ or $\sqrt{3}\sigma_{12} = \sqrt{3}S_{12}$ and the arc length $\Delta s = s - s_0$ relating to $s_0 \leq s$ for the group D through G is shown in Fig. 2 or Fig. 3. The

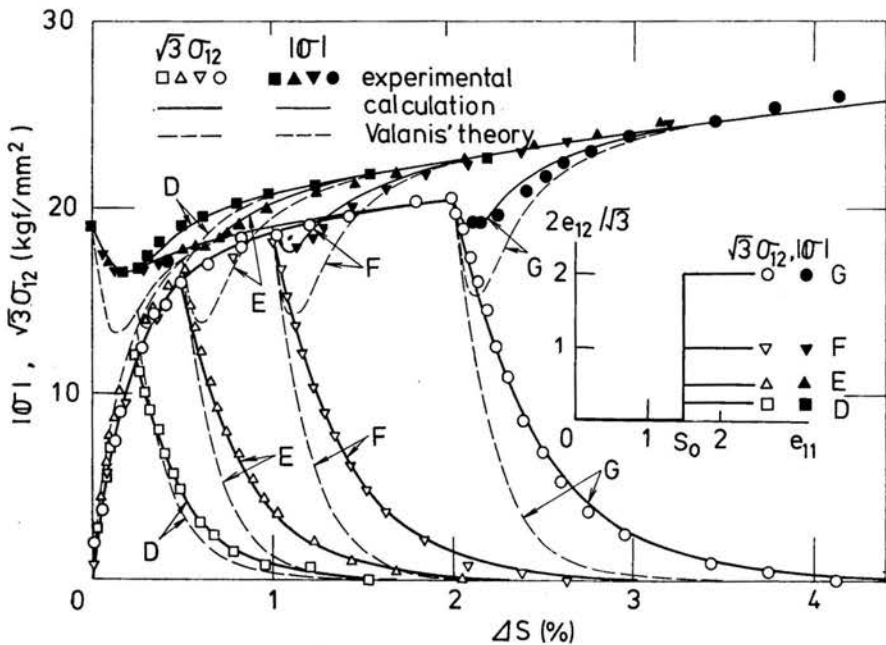

FIG. 3. Comparison of calculated results with experimental ones for group $D-G(|\sigma^*|, \sqrt{3}\sigma_{12})$.

thick solid curve corresponds to the calculated result, and the various kinds of points show the corresponding experimental ones along the trajectories indicated by the inserted small figure. The thin solid curves in Fig. 3 show the relation between the resultant modified stress intensity $|\sigma^*| = \sqrt{\sigma_{11}^{*2} + 3\sigma_{12}^2}$ and Δs found from the thick curves in Figs. 2 and 3. Figures 4 and 5 show analogous curves for the group H through L as compared with the corresponding experimental results. As found from these figures, the calculated results may approximate the corresponding experimental ones with high accuracy.

The dashed curves in Figs. 2 and 3 show the results calculated by VALANIS' method [7] briefly mentioned above. There are considerable differences between the solid and dashed curves.

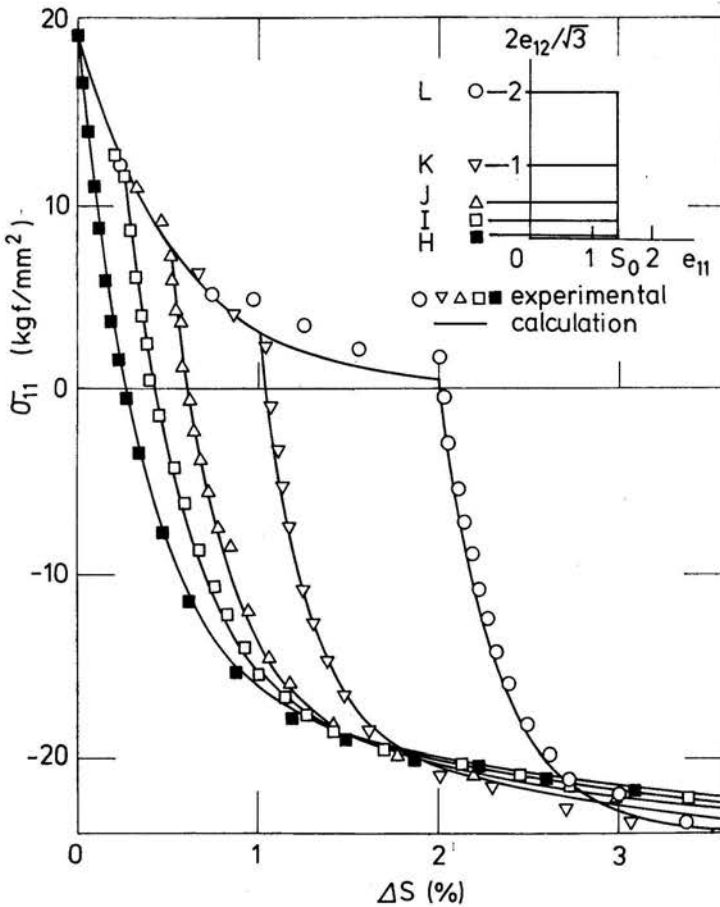

FIG. 4. Comparison of calculated results with experimental ones for group $H-L(\sigma_{11})$.

5. Relation between fading memory and limit of integration

As found from the experimental results, the stress-strain relations of materials just after the corner of the strain trajectory are subjected to a severe history effect and the effect decreases with an increase of deformation thereafter without severe history effects. By taking this trend into account, Ilyushin proposed Eq. (1.3) instead of Eq. (1.2). Since the suitable choice of the length h of the "trace of delay" included in Eq. (1.3) has a significant meaning for effective use of the stress-strain relation obtained above in accurate analyses of plastic deformation of structures, a reasonable estimation of the length h will be discussed in the following.

When the trend of fading memory is assumed in the form of the exponential type, the effect of preceding disturbance to the instant considered, though it decreases with an increase of the interval between the relevant two instants, does not vanish completely for the finite interval. Thus the concept of the trace of delay is an approximation and

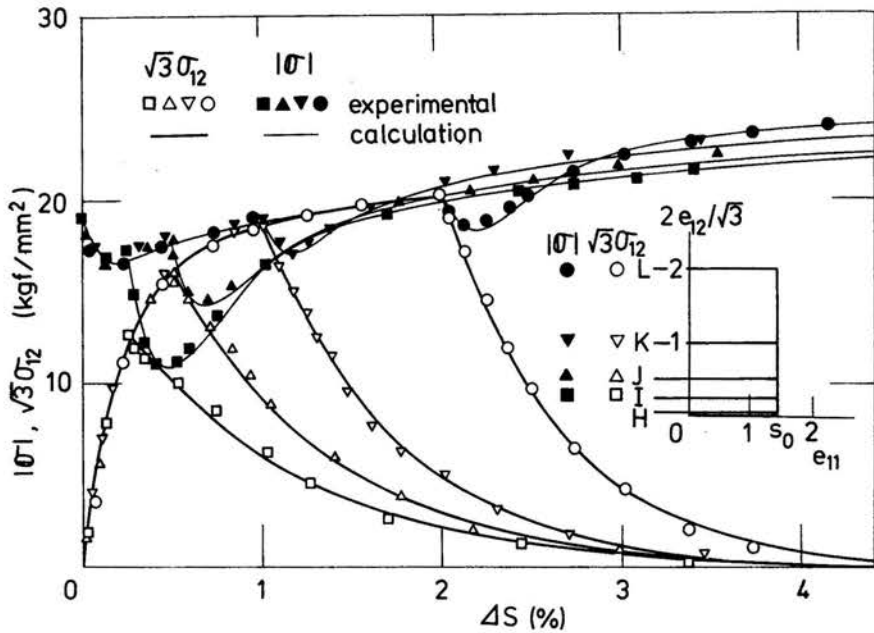

FIG. 5. Comparison of calculated results with experimental ones for group I-L ($|\sigma|$, $\sqrt{3}\sigma_{12}$).

the length h may be regarded to depend on the deformation history as well as on the materials. The length h should be determined in complying with the accuracy required for the calculated results. On the other hand, this concept is very effective for simplifying calculations for complicated history, and thus the necessity to discuss the relation between h and the accuracy of corresponding calculation should be emphasized for establishing the general plastic theory.

In the following, the relation is discussed according to the examples mentioned above.

5.1. Stress-strain relation within the length h along the strain trajectory consisting of three normal branches

The stress-strain relation within the length h may be expressed in the following manners.

Along the first branch:

$$(5.1) \quad S_{11}(s) = \frac{2}{3} \mu_a e^{-z_a(s)} \int_{s-h}^s e^{-z_a(s')} \frac{de_{11}}{ds'} ds'$$

Along the second branch:

$$(5.2) \quad S_{11}(s) = \begin{cases} \frac{2}{3} \mu_b e^{-z_b(s)} \int_{s-h}^{s_0} e^{z_b(s')} \frac{de_{11}}{ds'} ds', & (s-h \leq s_0), \\ 0, & (s_0 < s-h); \end{cases}$$

$$(5.2) \quad (cont.) \quad S_{12}(s) = \begin{cases} \frac{2}{3} \mu_b e^{-z_{b\beta}(s)} \int_{s_0}^s e^{z_{b\beta}(s')} \frac{de_{12}}{ds'} ds', & (s-h \leq s_0), \\ \frac{2}{3} \mu_b e^{-z_{b\beta}(s)} \int_{s-h}^s e^{z_{b\beta}(s')} \frac{de_{12}}{ds'} ds', & (s_0 < s-h). \end{cases}$$

When the value of S_{11} concerning h at $s = s_0$ is indicated by a symbol σ'_0 , σ'_0 is known from Eq. (5.1), and the following expression

$$(5.3) \quad \int_{s_0-h}^{s_0} e^{z_{b\alpha}(s')} \frac{de_{11}}{ds'} ds' = \frac{3\sigma'_0}{2\mu_b} e^{z_{b\alpha}(s_0)}$$

may be found from the relation

$$\sigma'_0 = \frac{2}{3} \mu_b e^{-z_{b\alpha}(s_0)} \int_{s_0-h}^{s_0} e^{z_{b\alpha}(s')} \frac{de_{11}}{ds'} ds'$$

obtained from Eq. (5.2)₁. By substituting Eq. (5.3) into Eq. (5.2), the following relations may be obtained:

$$(5.4) \quad \begin{aligned} S_{11}(s) &= \\ &= \begin{cases} \sigma'_0 e^{-\{z_{b\alpha}(s) - z_{b\alpha}(s_0)\}} \left[1 - \int_{s_0-h}^{s-h} e^{z_{b\alpha}(s')} \frac{de_{11}}{ds'} ds' \right] / \int_{s_0-h}^{s_0} e^{z_{b\alpha}(s')} \frac{de_{11}}{ds'} ds', & (s-h \leq s_0), \\ 0, & (s_0 < s-h), \end{cases} \\ S_{12}(s) &= \begin{cases} \frac{2}{3} \mu_b e^{-z_{b\beta}(s)} \int_{s_0}^s e^{z_{b\beta}(s')} \frac{de_{12}}{ds'} ds', & (s-h \leq s_0), \\ \frac{2}{3} \mu_b e^{-z_{b\beta}(s)} \int_{s-h}^s e^{z_{b\beta}(s')} \frac{de_{12}}{ds'} ds', & (s_0 \leq s-h). \end{cases} \end{aligned}$$

In the same manner, the following relations are obtained along the third branch:

$$(5.5) \quad \begin{aligned} S_{11}(s) &= \sigma'_1 e^{-\{z_{c\alpha}(s) - z_{c\alpha}(s_0+s_1)\}} \left[1 - \int_{s_0+s_1-h}^{s-h} e^{z_{c\alpha}(s')} \frac{de_{11}}{ds'} ds' \right] \\ &\quad / \int_{s_0+s_1-h}^{s_0} e^{z_{c\alpha}(s')} \frac{de_{11}}{ds'} ds' + \frac{2}{3} \mu_c e^{-z_{c\gamma}(s)} \int_{s_0+s_1}^s e^{z_{c\gamma}(s')} \frac{de_{11}}{ds'} ds', \quad (s-h \leq s_0), \\ S_{11}(s) &= \frac{2}{3} \mu_c e^{-z_{c\gamma}(s)} \int_{s_0+s_1}^s e^{z_{c\gamma}(s')} \frac{de_{11}}{ds'} ds', \quad (s_0 < s-h \leq s_0+s_1), \end{aligned}$$

$$(5.5) \quad S_{11}(s) = \frac{2}{3} \mu_c e^{-z_{c\gamma}(s)} \int_{s-h}^s e^{z_{c\gamma}(s')} \frac{de_{11}}{ds'} ds', \quad (s_0 + s_1 < s-h);$$

(cont.)

$$S_{12}(s) = \tau_1 e^{-\{z_{c\beta}(s) - z_{c\beta}(s_0 + s_1)\}}, \quad (s-h \leq s_0),$$

$$S'_{12}(s) = \tau'_1 e^{-\{z_{c\beta}(s) - z_{c\beta}(s_0 + s_1)\}} \left[1 - \int_{s_0 + s_1 - h}^{s-h} e^{z_{c\beta}(s')} \frac{de_{12}}{ds'} ds' \right] \left/ \int_{s_0 + s_1 - h}^{s_0 + s_1} e^{z_{c\beta}(s')} \frac{de_{12}}{ds'} ds' \right.,$$

$$(s_0 < s-h \leq s_0 + s_1),$$

$$S_{12}(s) = 0, \quad (s_0 + s_1 < s-h),$$

where σ'_1 and τ'_1 are expressed as follows:

$$(5.6) \quad \sigma'_1 = \frac{2}{3} \mu_c e^{-z_{c\alpha}(s_0 + s_1)} \int_{s_0 + s_1 - h}^{s_0} e^{z_{c\alpha}(s')} \frac{de_{11}}{ds'} ds',$$

$$\tau'_1 = \frac{2}{3} \mu_c e^{-z_{c\beta}(s_0 + s_1)} \int_{s_0 + s_1 - h}^{s_0 + s_1} e^{z_{c\beta}(s')} \frac{de_{12}}{ds'} ds'.$$

The corresponding values of μ and z in the above formulae are the same as those shown in Tables 1 through 3.

Table 2. Values of μ and z for the third branch: Group D-G

μ_c (kgf/mm ²)	z	s_1 (%)	a	b	c
10010	$z_{c\alpha} = z_{c\gamma}$		4.64×10^{-3}	0.259	8.12×10^{-3}
	$z_{c\beta}$	0.25	2.71×10^{-3}	0	0
		0.5	3.47×10^{-3}	0	0
		1.0	3.92×10^{-3}	0	0
		2.0	4.76×10^{-3}	0	0

Table 3. Values of μ and z for the third branch: Group H-L

s_1	μ_c (kgf/mm ²)	z	a	b	c
0	4500	$z_{c\alpha} = z_{c\gamma}$	13.92×10^{-3}	4.28×10^{-2}	2.59×10^{-2}
		$z_{c\beta}$	1.75×10^{-3}	0	0
0.25	4850	$z_{c\alpha} = z_{c\gamma}$	12.74×10^{-3}	4.20×10^{-2}	2.51×10^{-2}
		$z_{c\beta}$	2.71×10^{-3}	0	0
0.5	5500	$z_{c\alpha} = z_{c\gamma}$	11.32×10^{-3}	4.15×10^{-2}	2.39×10^{-2}
		$z_{c\beta}$	3.47×10^{-3}	0	0
1.0	6600	$z_{c\alpha} = z_{c\gamma}$	9.41×10^{-3}	3.98×10^{-2}	2.14×10^{-2}
		$z_{c\beta}$	3.92×10^{-3}	0	0
2.0	7500	$z_{c\alpha} = z_{c\gamma}$	8.03×10^{-3}	3.60×10^{-2}	1.67×10^{-2}
		$z_{c\beta}$	4.76×10^{-3}	0	0

5.2. Relation between the range of integration and accuracy of calculation

It is necessary to shorten the arc length h for simplifying calculations whereas it is desirable to take h as long as possible for improving the accuracy of calculation. In order to determine the arc length h for general application by taking these two points of view into account, stress components were calculated along the trajectories of the group D through G in relation to four values of $h = 0.5, 1.0, 1.5$ and 2.0 per cent, for example.

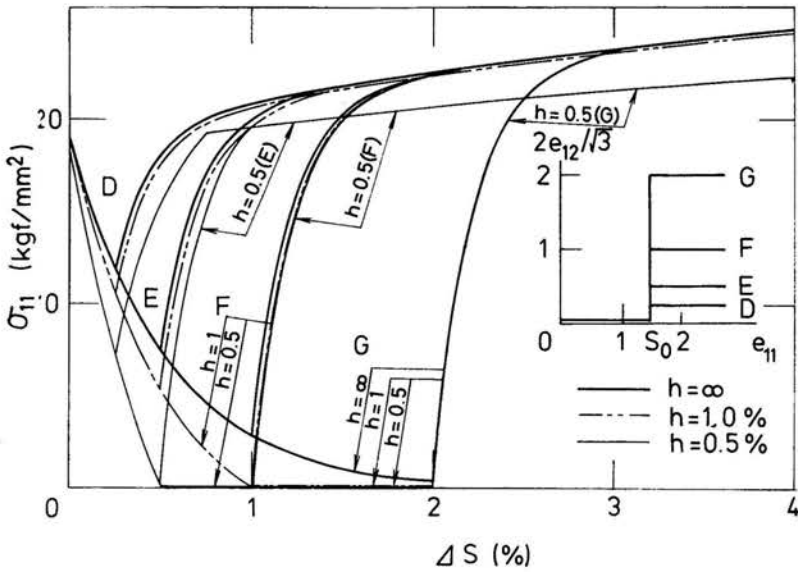

FIG. 6. Relation between range of integration and accuracy of calculation (σ_{11}): $h = \infty, 1.0, 0.5\%$.

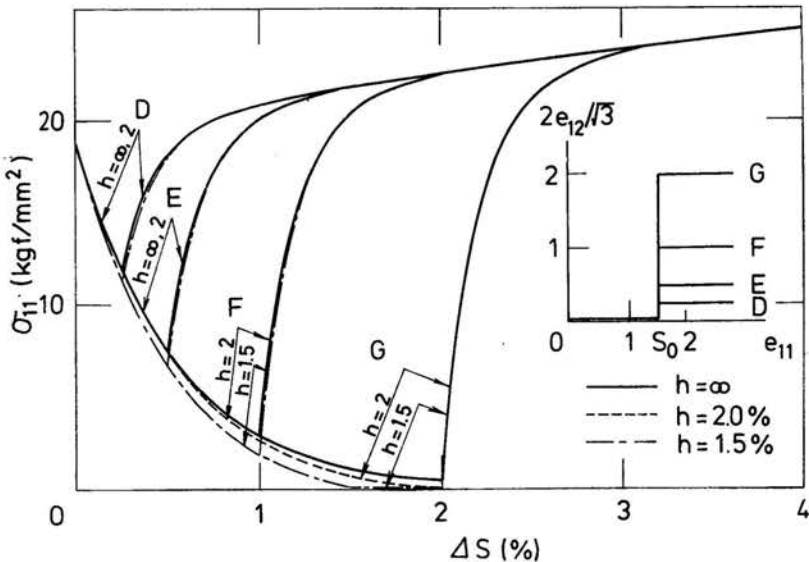

FIG. 7. Relation between range of integration and accuracy of calculation (σ_{11}): $H = \infty, 2.0, 1.5\%$.

As examples of the results obtained, Figs. 6 and 7 show the relations between $\sigma_{11} = (3/2)S_{11}$ and the arc length Δs after the first corner of the trajectories. Moreover, Fig. 8 shows analogous relations between $\sqrt{3}\sigma_{12}$ and Δs . In these figures the results of calculation without considering the trace of delay ($h \rightarrow \infty$) are shown with the solid curves, and the results for $h = 2.0, 1.5, 1.0$ and 0.5 per cent correspond to the dashed curve, dot and dashed curve, double dot and dashed curve and thin solid curve, respectively. In Fig. 8

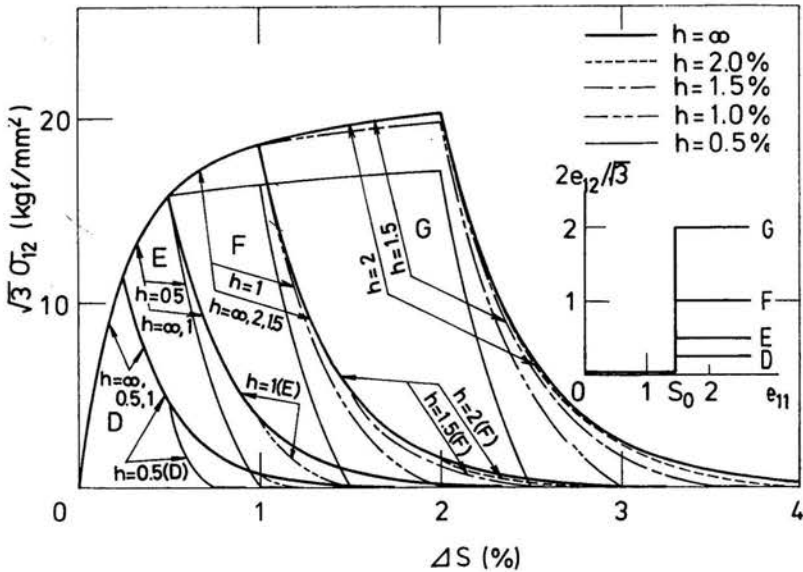

FIG. 8. Relation between range of integration and accuracy of calculation ($\sqrt{3}\sigma_{12}$): $h = \infty, 1.5, 1.0, 0.5\%$.

the results relating to $h = 1.5$ and 2.0 per cent almost coincided with those for $h \rightarrow \infty$ along the trajectories D and E for $s_1 = 0.25$ and 0.5 per cent, and these results are not entered in the figure.

As found from Figs. 6 and 8, there is a considerable difference between the results relating to $h = 0.5$ or 1.0 per cent and $h \rightarrow \infty$. However, it is found from Figs. 7 and 8 that the results relating to $h = 1.5$ and 2.0 per cent agree well with the results relating to $h \rightarrow \infty$. Judging from these results it may be concluded that the accuracy of calculation is not sufficient for practical use and depends on the geometry of the trajectory for a length h less than 1.5 per cent, but it is sufficient for estimating stress value independently of the geometry of the strain trajectory for the length h longer than 1.5 per cent.

6. Conclusion

In order to formulate systematically the stress-strain relation for the plastic deformation of metals with high accuracy by taking into account the history effect appearing in their deformation behaviour, a method having a logically clear foundation was established by selecting the methods with a reasonable foundation out of the methods which have been proposed up to the present.

Experimental results obtained on the plastic deformation of brass, in which a thin-walled tubular specimen was deformed with a constant strain rate along the strain trajectory with three normal straight branches under combined loading of torsion and axial force, were formulated by using this method in the form of a stress-strain relation.

The results calculated by the relation were confirmed to approximate the experimental results with high accuracy. Further, for simplifying the calculation, an effective range of trajectory to be taken into account for establishing the relation was discussed in a typical case of the above-mentioned trajectory. It was ascertained to be sufficient to consider the geometry of the trajectory preceding as far as 1.5 per cent to the point considered.

Though the proposed method is effective for a material with a nonlinear continuous stress-strain curve such as brass, aluminium alloy and others, it may be applicable for every continuous part of a stress-strain curve of mild steel except the initial discrete yield range.

The example of a strain trajectory mentioned is rather a special case in which a remarkable history effect appears. The stress-strain relation which should be used for the accurate elastoplastic deformation analyses of engineering structures may also be formulated by taking into account the variations of geometric parameters in the range of the length h for various cases appearing in the process of deformation analyses.

Acknowledgement

The paper presents a part of our experimental work conducted in line with the "Memorandum on Scientific Collaboration and Outline of Cooperative Research Programme" interchanged between the Institute of Fundamental Technological Research of the Polish Academy of Sciences and the Department of Mechanical Engineering of Nagoya University.

References

1. A. A. ИЛЬЮШИН, *Вопросы теории пластичности*, Изд. АН СССР, Москва 1961, 3: *Пластичность*, Изд. АН СССР, 101, Москва 1963.
2. Y. OHASHI, M. TOKUDA, *Trans. JSME*, **39**, 317, 95, 1974 [in Japanese].
3. Y. OHASHI, M. TOKUDA, *J. Mech. Phys. Solids*, **21**, 241, 1973.
4. Y. OHASHI *et al.*, *Trans. JSME*, **41**, 341, 96, 1976 [in Japanese].
5. Y. OHASHI *et al.*, *J. Mech. Phys. Solids*, **23**, 295, 1975.
6. Y. C. FUNG, *Foundations of solid mechanics*, Prentice-Hall, Englewood Cliffs 1965.
7. K. C. VALANIS, *Arch. Mech.*, **23**, 4, 517, 1971.
8. Y. OHASHI *et al.*, *Trans. JSME*, **40A**, 1575, 1979 [in Japanese].
9. Y. OHASHI *et al.*, *Trans. JSME*, **43**, 374, 3732, 1977 [in Japanese].

DEPARTMENT OF MECHANICAL ENGINEERING
NAGOYA UNIVERSITY, NAGOYA

and

DEPARTMENT OF MECHANICAL ENGINEERING
MIE UNIVERSITY, TSU CITY, JAPAN.

Received December 14, 1978.