

## Elastic wave propagation in a two-component composite structure

M. SOKOŁOWSKI and Z. WESOŁOWSKI (WARSZAWA)

PROPAGATION of longitudinal elastic waves is considered in a model of composite structure consisting of two rods made of different materials interconnected by means of elastic springs. Wave profiles are evaluated numerically from the accurate integral formulae (8).

Rozważa się propagację podłużnych fal sprężystych w modelu konstrukcji złożonej z dwóch prętów wykonanych z różnych materiałów i połączonych sprężynkami. Kształty fal wyznaczono numerycznie ze ścisłych wzorów całkowych (8).

Рассматривается распространение продольных упругих волн в модели конструкции состоящей из двух стержней, изготовленных из разных материалов, и соединенных пружинками. Формы волн определены численно из точных интегральных формул (8).

LET US CONSIDER the problem of propagation of longitudinal elastic waves in a composite structure consisting of two rods made of different elastic materials interacting with each other with forces proportional to the difference of their longitudinal displacements.

The problem was formerly considered by one of the authors in the paper [1]; however, the numerical analysis applied in that paper did not give satisfactory results concerning the accurate profiles of elastic waves propagating in both rods. The problem will now be analyzed in a slightly different manner, with the use of the integral transforms technique.

A model of such a structure is shown in Fig. 1: two rods characterized by Young's moduli  $E_1, E_2$  and densities  $\rho_1, \rho_2$  are interconnected by means of elastic springs (Fig. 1a) transmitting longitudinal forces of intensity

$$(1) \quad \tau = \kappa(u-v)$$

(Fig. 1b), where  $u = u(x, t), v = v(x, t)$  denote axial displacements of the respective rods and  $\kappa$  is the spring constant. In order to eliminate possible bending effects, the cross-

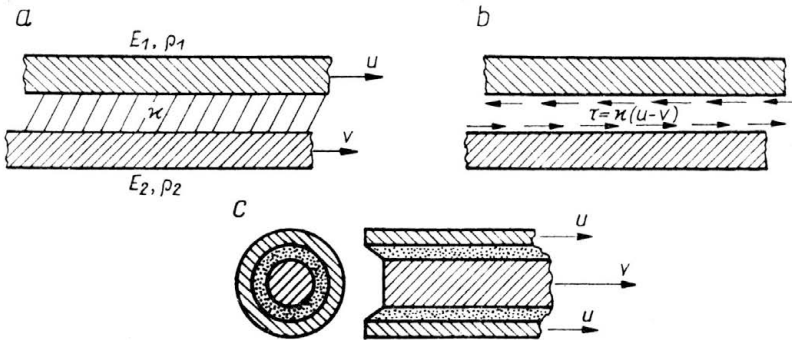

FIG. 1.

section of the composite rod should actually be symmetric; for instance, it may be assumed in the form of an elastic tube and core separated by a filling material (rubber, grease etc.) transmitting the required interaction forces (1.1), Fig. 1c. By assuming the problem to be strictly one-dimensional (no transversal displacements or interaction forces), the equations of motion of the model shown in Fig. 1 are written in the form

$$(2) \quad \begin{aligned} E_1 \frac{\partial^2 u}{\partial x^2} - \rho_1 \frac{\partial^2 u}{\partial t^2} - \kappa(u-v) &= 0, \\ E_2 \frac{\partial^2 v}{\partial x^2} - \rho_2 \frac{\partial^2 v}{\partial t^2} + \kappa(u-v) &= 0. \end{aligned}$$

Apply now the Laplace transform to Eqs. (2); using the notation

$$\begin{aligned} \bar{u}(x, p) &= \mathcal{L}\{u\} = \int_0^{\infty} e^{-pt} u(x, t) dt, \\ \bar{v}(x, p) &= \mathcal{L}\{v\}, \end{aligned}$$

where  $p$  is the complex transform parameter, Eqs. (2) are rewritten in the form

$$(3) \quad \begin{aligned} c_1^2 \frac{\partial^2 \bar{u}}{\partial x^2} - p^2 \bar{u} + k_1^2 (\bar{v} - \bar{u}) &= -F_1(x, p), \\ c_2^2 \frac{\partial^2 \bar{v}}{\partial x^2} - p^2 \bar{v} + k_2^2 (\bar{u} - \bar{v}) &= -F_2(x, p). \end{aligned}$$

Here  $c_i = \sqrt{E_i/\rho_i}$ ,  $i = 1, 2$ , are propagation speeds,  $k_i^2 = \kappa/\rho_i$ , and functions  $F_i(x, p)$  are determined by initial conditions of the problem

$$(4) \quad \begin{aligned} F_1(x, p) &= \dot{u}(x, 0) + pu(x, 0), \\ F_2(x, p) &= \dot{v}(x, 0) + pv(x, 0). \end{aligned}$$

In order to simplify the considerations as much as possible, assume the displacements  $u(x), v(x)$  to be symmetric in  $x$ ,  $u(x, t) = u(-x, t)$ ,  $v(x, t) = v(-x, t)$ ; it follows that the axial stresses in the rods,  $E_1 \partial u/\partial x$  and  $E_2 \partial v/\partial x$ , vanish at  $x = 0$ ; this takes place when a semi-infinite rod  $0 < x < \infty$  with a stress-free end  $x = 0$  is considered. Under this assumption, the integral cosine-transforms  $\bar{u}^*$ ,  $\bar{v}^*$ ,  $F_i^*$  of displacements  $\bar{u}$ ,  $\bar{v}$  and functions  $F_i$  may be introduced:

$$(5) \quad \begin{aligned} \bar{u}(x, p) &= \int_0^{\infty} \bar{u}^*(\alpha, p) \cos \alpha x d\alpha, \\ \bar{v}(x, p) &= \int_0^{\infty} \bar{v}^*(\alpha, p) \cos \alpha x d\alpha, \\ F_i(x, p) &= \int_0^{\infty} F_i^*(\alpha, p) \cos \alpha x d\alpha. \end{aligned}$$

On introducing the expressions (5) into the differential equations (3), the problem is easily solved for  $\bar{u}^*(\alpha, p)$  and  $\bar{v}^*(\alpha, p)$  to yield

$$(6) \quad \begin{aligned} \bar{u}^*(\alpha, p) &= \frac{\Omega_2 F_1^* + k_1^2 F_2^*}{\Omega_1 \Omega_2 - k_1^2 k_2^2}, \\ \bar{v}^*(\alpha, p) &= \frac{\Omega_1 F_2^* + k_2^2 F_1^*}{\Omega_1 \Omega_2 - k_1^2 k_2^2}, \end{aligned}$$

with the notation  $\Omega_i = \Omega_i(\alpha, p) = p^2 + \alpha^2 c_i^2 + k_i^2$ .

Inversion of the double transforms (6) would be possible under very special assumptions as to the physical conditions of the problem under consideration. Partial inversion of those formulae will be presented for the case of initial conditions

$$u(x, 0) \equiv v(x, 0) \equiv 0, \quad \dot{u}(x, 0) = \dot{v}(x, 0) = g_0 \delta(x),$$

where  $\delta(x)$  is Dirac's delta; then  $F_i^*(\alpha) = g_0/\pi$ .

Assume now that  $k_2 > k_1$  and  $c_2 > c_1$ . Introducing further notations

$$(7) \quad \begin{aligned} \hat{k}^2 &= \frac{1}{2}(k_1^2 + k_2^2), & \bar{k}^2 &= \frac{1}{2}(k_2^2 - k_1^2), \\ \hat{c}^2 &= \frac{1}{2}(c_1^2 + c_2^2), & \bar{c}^2 &= \frac{1}{2}(c_2^2 - c_1^2), \\ \Phi^2 &= (\bar{k}^2 + \alpha^2 \bar{c}^2)^2 + k_1^2 k_2^2, \\ A^2 &= \hat{k}^2 + \alpha^2 \hat{c}^2 + \Phi, & B^2 &= \hat{k}^2 + \alpha^2 \hat{c}^2 - \Phi, \\ M_1 &= 1 + \frac{1}{\Phi}(\hat{k}^2 + \alpha^2 \bar{c}^2), & M_2 &= 1 + \frac{1}{\Phi}(\hat{k}^2 - \alpha^2 \bar{c}^2), \\ N_1 &= 1 - \frac{1}{\Phi}(\hat{k}^2 + \alpha^2 \bar{c}^2), & N_2 &= 1 - \frac{1}{\Phi}(\hat{k}^2 - \alpha^2 \bar{c}^2), \end{aligned}$$

the formulae (6) may be partly inverted to yield

$$(8) \quad \begin{aligned} u(x, t) &= \frac{g_0}{2\pi} \int_0^\infty \left( \frac{M_1 \sin Bt}{B} + \frac{N_1 \sin At}{A} \right) \cos \alpha x \, d\alpha, \\ v(x, t) &= \frac{g_0}{2\pi} \int_0^\infty \left( \frac{M_2 \sin Bt}{B} + \frac{N_2 \sin At}{A} \right) \cos \alpha x \, d\alpha. \end{aligned}$$

The integrals (8) representing elastic displacement waves travelling along the composite rod cannot be written in explicit forms except for certain particular cases. For instance, if  $k_1 = k_2 = 0$ , that is when the model consists of two different but separate rods subject to identical boundary and initial conditions, in view of  $\hat{k} = \bar{k} = 0$ ,  $\Phi = \alpha^2 \bar{c}^2$ ,  $A = \alpha c_2$ ,  $B = \alpha c_1$ ,  $M_1 = N_2 = 2$ ,  $M_2 = N_1 = 0$ , one obtains (cf. [2])

$$\begin{aligned} u(x, t) &= \frac{g_0}{2\pi} \int_0^\infty \frac{2 \sin \alpha c_1 t \cos \alpha x \, d\alpha}{\alpha c_1} = \frac{g_0}{2c_1} \eta(c_1 t - x), \\ v(x, t) &= \frac{g_0}{2c_2} \eta(c_2 t - x), \end{aligned}$$

$\eta(c_i t - x)$  denoting the Heaviside function. This is the known solution representing two separate elastic waves of constant displacements  $g_0/2c_i$  travelling at the respective speeds  $c_i$  along both semi-infinite rods  $0 < x < \infty$ . Similarly, in the case when  $k_1 = k_2 = k$ ,  $c_1 = c_2 = c$  (two identical, interconnected rods), both waves are identical and travel at the same speed  $c$ ,  $u = v = \frac{g_0}{2c} \eta(ct - x)$ , what should be expected.

Finally, consider another simple but not trivial case of  $c_1 = c$ ,  $c_2 = 2c$ . Introducing new space and time variables:  $\bar{x} = x/a$  (dimensionless distance) and  $\bar{t} = t/a$ , where  $a$  denotes a unit of length, assuming  $a = 1$ ,  $c = 1$ , and putting  $k_1 a = k_2 a = 2$ , the formulae (7) are reduced to

$$\begin{aligned} \hat{k} &= 2, & \bar{k} &= 0, & \hat{c}^2 &= 2.5, & \bar{c}^2 &= 1.5 & \Phi &= 1.5 \sqrt{\alpha^4 + N^4}, \\ N &= \sqrt{8/3}, & A^2 &= 4 + 2.5\alpha^2 + 1.5 \sqrt{\alpha^4 + N^4}, \\ B^2 &= 4 + 2.5\alpha^2 - 1.5 \sqrt{\alpha^4 + N^4}, \\ M_1 &= 1 + \frac{4 + 1.5\alpha^2}{1.5 \sqrt{\alpha^4 + N^4}}, & M_2 &= 1 + \frac{4 - 1.5\alpha^2}{1.5 \sqrt{\alpha^4 + N^4}}, \\ N_1 &= 1 - \frac{4 + 1.5\alpha^2}{1.5 \sqrt{\alpha^4 + N^4}}, & N_2 &= 1 - \frac{4 - 1.5\alpha^2}{1.5 \sqrt{\alpha^4 + N^4}}. \end{aligned}$$

The integrals (8) are computer-evaluated and lead to the results presented in Figs. 2, 3, 4 and 5.

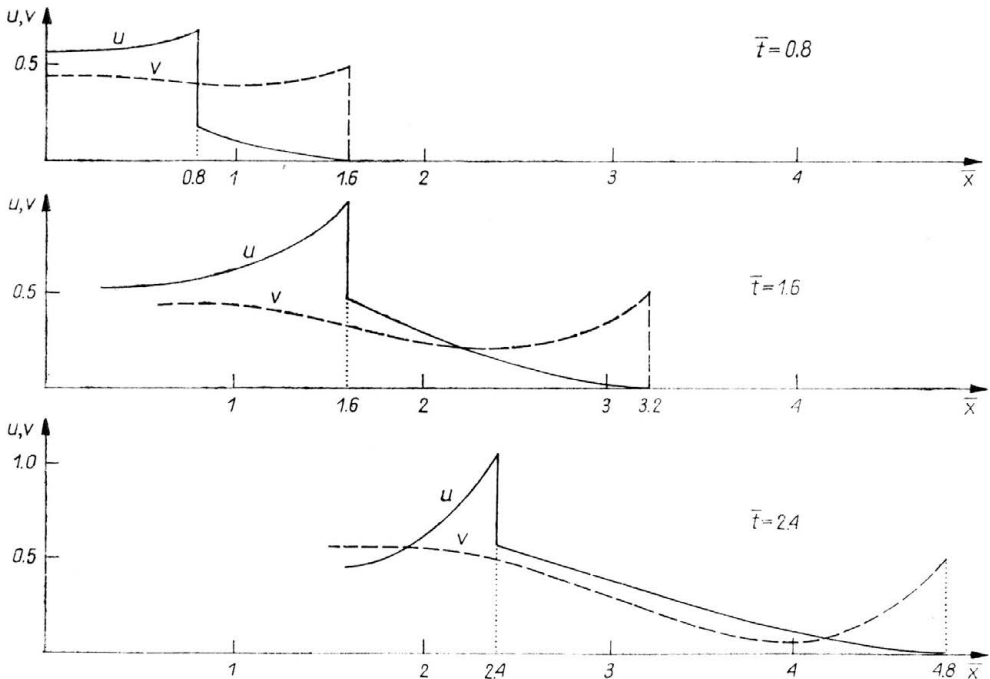

FIG. 2.

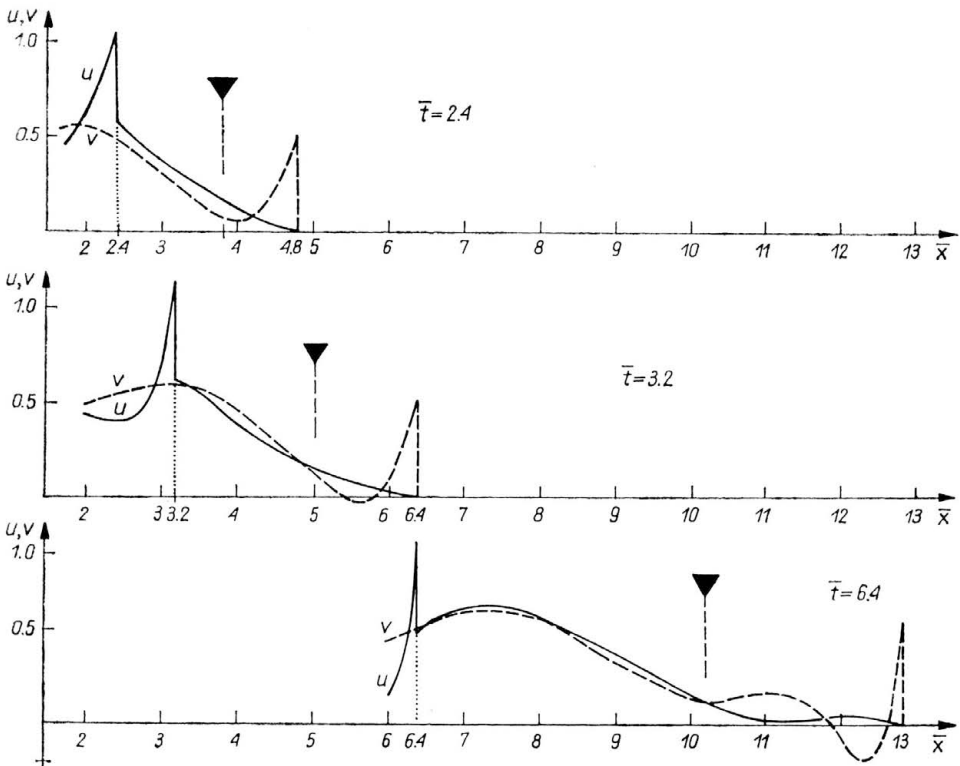

FIG. 3.

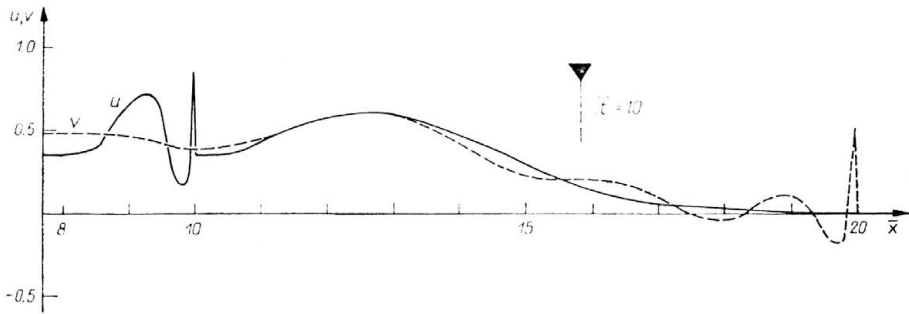

FIG. 4.

Figure 2 corresponds to relatively short times ( $\bar{t} = 0.8, \bar{t} = 1.6, \bar{t} = 2.4$ ). Solid lines denote displacements  $u$  in the first rod, dashed lines — displacements  $v$  in the second rod,  $c_1 = 1$  and  $c_2 = 2$ . At small times  $\bar{t} \rightarrow 0$  both displacements are represented by Heaviside's functions. At  $\bar{x} = \bar{t}$  only displacement  $u$  is discontinuous, the jump being independent of  $\bar{t}$  and equal to  $1/2$ ; At  $\bar{x} = 2\bar{t}$  only  $v$  is discontinuous and exhibits the same

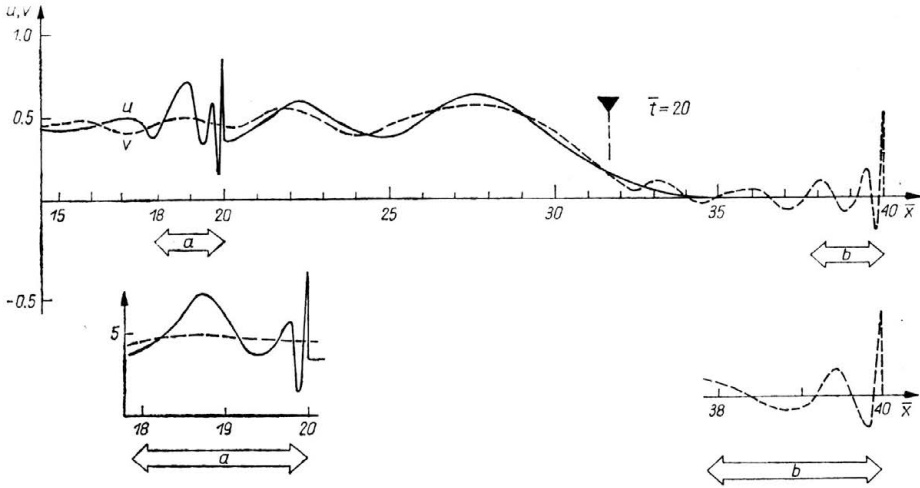

FIG. 5.

discontinuity  $1/2$ ; at that point the first displacement  $u$  vanishes. For larger values of  $\bar{t}$  (Figs. 3, 4 and 5) an interval of the rod may be observed along which both displacements are approximately the same,  $u \approx v$ . This confirms the observation made in [1] according to which for large values of time, in addition to separate waves travelling in both rods, a “common” wave is also propagated at a speed approximately equal to

$$c_0 = \sqrt{\frac{c_1^2 + c_2^2}{2}}.$$

The approximate position of that “common wave-front” is marked in Figs. 3, 4 and 5 by triangles.

Unexpected oscillatory curves appear in the neighbourhood of two displacement discontinuities (wave fronts)  $\bar{x} = c_1 \bar{t}$  and  $\bar{x} = c_2 \bar{t}$  for larger values of time (larger distances from the end of the composite rod). For instance, observe such phenomena in the intervals  $18 < \bar{x} < 20$  and  $34 < \bar{x} < 40$  in Fig. 5 corresponding to time  $\bar{t} = 20$ .

In order to verify this phenomenon, let us consider two graphs presented in Fig. 6 a, b. Contrary to the preceding ones, the curves correspond to fixed values of  $x$  and variable time  $t$ , for which displacement  $u$  of the first rod has been evaluated numerically. At times  $\bar{t} < \bar{x}/c_2$  displacement  $u \equiv 0$  (in case of Fig. 6a  $\bar{x} = 2$ , and in case of Fig. 6b  $\bar{x} = 4$ ). At the instant  $\bar{t} = \bar{x}/c_2$  displacement  $u$  starts to increase due to the motion transmitted from the second rod in which the wave propagates at speed  $c_2 > c_1$ . At  $\bar{t} = \bar{x}/c_1$ , the displacement discontinuity  $[u] = 0.5$  propagating along the first rod appears. Comparison of the right-hand portions of curves shown in Figs. 6a and 6b confirms the previously observed tendency of oscillatory motion of rods close to the wave fronts, the tendency which is seen to intensify with increasing distances from the end of the rod.

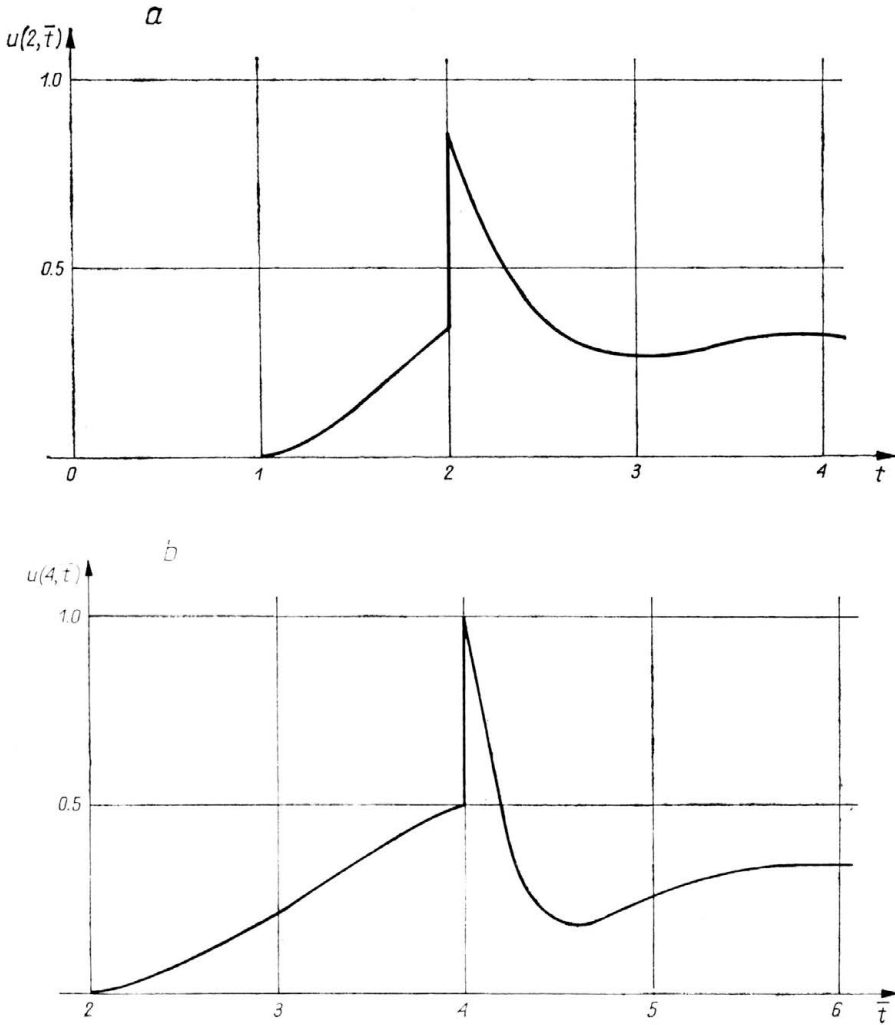

FIG. 6.

## References

1. Z. WESOŁOWSKI, *One-dimensional model of composite material*, Arch. Mech., **36**, 3, 407-414, 1984.
2. A. ERDÉLYI *et al.*, *Tables of integral transforms*, vol. 1, McGraw-Hill Book Company, New York-Toronto-London, 1954.

POLISH ACADEMY OF SCIENCES  
INSTITUTE OF FUNDAMENTAL TECHNOLOGICAL RESEARCH.

Received January 13, 1988.