

MAREK DWORACZYK, BEATA WYWROT-WYSZKOWSKA

## WATER SUPPLY AND DISPOSAL OF ITS SURPLUS IN MEDIEVAL AND EARLY MODERN KOŁOBRZEG

Sources which were acquired in the course of excavation research in the area of late medieval Kołobrzeg are both enormously rich and diversified with regard to their assortment. Based on these, it is possible to undertake manifold studies on various aspects of life in the town. Among the finds, special attention should be paid to remains of medieval and modern period water supplying and dewatering devices (Fig. 1). These are invaluable sources for studying numerous issues related to water management in the town. When dealing with waterworks and dewatering devices in Kołobrzeg it is worth briefly discussing the natural environment where the town originated and developed. It must be remembered that the lay of the land, the geological structure and the hydrographical network essentially influenced the accessibility of water and conditioned the means of its supply. To a considerable degree, these conditions also decided on the way of disposing of its surplus. The late medieval location town was situated on the left bank of the River Parsęta on a small moraine hill. It was surrounded from the west with a wide river terrace and with the muddy river valley from the other sides. The valley itself was filled with peat and gyttia<sup>1</sup>. The terrain was marshy, with an abundance of watercourses and puddles.

### Water supply

Results of research on the original natural environment of Kołobrzeg and outcomes of excavation works enabled the researchers to point out three sources of water supply. Inhabitants of Kołobrzeg could draw water from the river and/or the town moat, from ponds and streams existing in the neighbourhood of the town in the Middle Ages, as well as make use of subsoil water<sup>2</sup>. All these ways were related to construction of appropriate water supplying devices.

<sup>1</sup> Z. Solek, L. Leciejewicz, *Z badań nad krajobrazem naturalnym wczesnośredniowiecznego Kołobrzegu*, „Kwartalnik Historii Kultury Materialnej”, vol. 9, No. 3, p. 388; M. Hofa, *Niektóre cechy fizyczno-geograficzne rejonu Kołobrzegu i ich znaczenie dla portu i uzdrowiska*, Poznań 1968, pp. 12-13; M. Rębkowski, *Topografia Kołobrzegu w XIII wieku*, [in:] *Słowiańszczyzna w Europie średniowiecznej*, ed. Z. Kurnatowska, Wrocław 1996, p. 127.

<sup>2</sup> M. Rębkowski, *The Infrastructure of Kołobrzeg*, [in:] *Lübecker Kolloquium zur Stadtarchäologie im Hanseraum IV: Die Infrastruktur*, ed. M. Gläser, Lübeck 2004, p. 364, with further reference.

As it can be said based on written sources, public wells were in use as early as in the 13<sup>th</sup> century. They were located in main streets, such as these corresponding to present-day Budowlana street, Gierczak street and Narutowicza street<sup>3</sup>. A precise location of these wells is regrettably unknown; it could be supposed that they were located at street junctions. In all probability, these wells were originally dug-out ones and they were supplied with subsoil water. Later on, as municipal waterworks were constructed, some of such wells may have been integrated into this system<sup>4</sup>. Public wells played a considerable role in supplying water to inhabitants. Some of such wells were in use as late as at the end of the 19<sup>th</sup> century, when modern waterworks were constructed in Kołobrzeg<sup>5</sup>.

Apart from public wells, private ones certainly existed. Due to a relatively high level of subsoil waters at that time, a construction of such wells was not particularly time- and labour-consuming<sup>6</sup>. As it can be said based on research on spatial layouts and buildings in medieval urban plots, various household buildings and structures, including wells and latrines, were usually situated in backyards<sup>7</sup>. Regrettably, not many backyards of plots have been examined so far and no features were found which could unambiguously be interpreted as wells. Wooden dug-in rectangular plan structures were found; their fills, however, strongly suggest that these were used (at least temporarily) as latrines. On the other hand, it seems plausible that two 14<sup>th</sup> century features found in 2A Market Square and 1 Ratuszowa street plots were originally

<sup>3</sup> H. Riemann, *Geschichte der Stadt Kolberg*, Kolberg 1924, p. 49.

<sup>4</sup> B. Wywrot-Wyszowska, *Średniowieczne i wczesnonowożytnie urządzenia wodociągowe w Kołobrzegu*, [in:] *Pomorze wczoraj-dziś-jutro. Miasta i miasteczka pomorskie*, ed. A. Majewska, Stargard-Pruszcz Gdański 2010, pp. 74-75.

<sup>5</sup> H. Riemann, *Geschichte der Stadt...*, p. 49; J. Kloskowski, *Studnie i wodociągi dawnego Koszalina*, „Koszalińskie Zeszyty Muzealne”, vol. 2 (1972), p. 107.

<sup>6</sup> Cf. U. Sowina, *Woda i ludzie w mieście późnośredniowiecznym i wczesnonowożytnym. Ziemia polskie z Europą w tle*, Warszawa 2009, p. 152.

<sup>7</sup> C. Buśko, *Zaplecze gospodarcze kamienicy mieszczkańskiej. Urządzenia wodno-kanalizacyjne*, [in:] *Architektura Wrocławia*, vol. 1, *Dom*, ed. J. Rozpędowski, Wrocław 1995, p. 89.

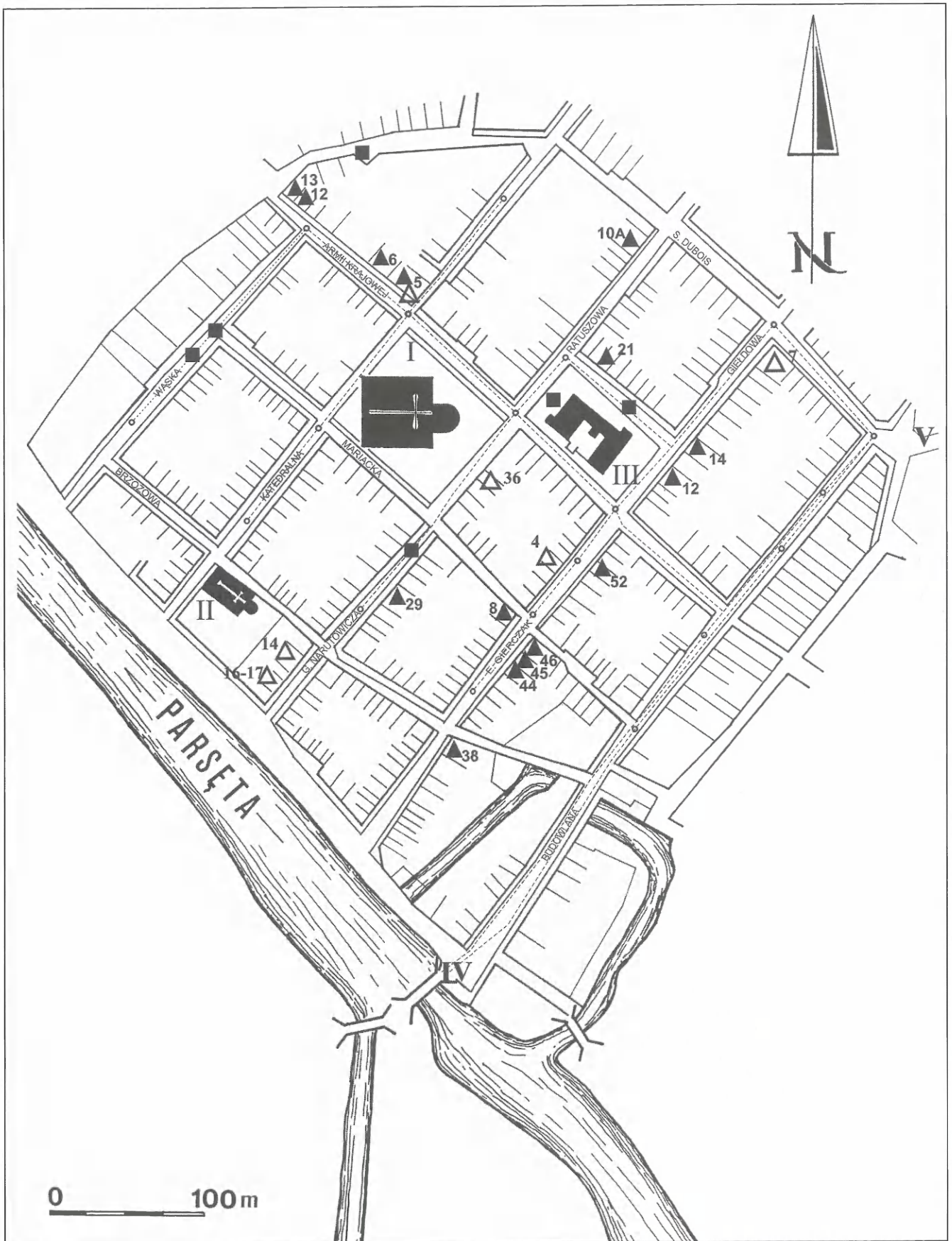

Fig. 1. Kolobrzeg. Location of discovered remains of medieval waterworks and the modern period waterworks against the background of the plan of the waterworks network. Features discovered during archaeological works were marked with triangles: medieval waterworks ( $\Delta$ ) and the modern period waterworks ( $\blacktriangle$ ). Features discovered accidentally were marked with squares. I – collegiate (parish) church; II – convent of Benedictine (from about 1468); III – City-hall; IV – location of Mill Gate; V – location of Stone Gate.  
 After B. Wywrot-Wyszowska 2010.



used as wells<sup>8</sup>. Both features were constructed on rectangular plans of 100 x 160 and 140 x 130 cm respectively. Linings of both wells were made of horizontally placed pine planks. The constructions were reinforced from inside with vertical pegs. These were fitted in the corners and roughly at the mid-length of each wall. Much less interpretation doubt is raised by a well (dated to the 16<sup>th</sup>-the 17<sup>th</sup> century) discovered within the buildings of the Holy Spirit Hospital (Fig. 2).

It was built on a rectangular plan (95 x 75 cm) of four oak planks. Lateral edges of the planks were joint using oak pegs. The construction was situated on planks which were laid down flat at the bottom of the ditch. Holes were bored in the lower parts of the plans in order to secure the inflow of water. The lower part of the well was surrounded with a rectangular casing made of thick pine planks. A water pump was installed inside the well<sup>9</sup>.

From the 17<sup>th</sup> century onwards bricks were used to build linings of dug-out wells. Several wells of that kind were discovered in the area of the town. These were situated in the backyards of plots, directly near the outbuildings (features from the plots of 10A Ratuszowa street, 2A and 21 Market Square – Fig. 3) or in the basements of houses (features from the plots of 12 Armii Krajowej street and 10 Market Square)<sup>10</sup>. Such wells were built using key bricks, laid with their headers forwards. Sometimes “standard” bricks were used; in order to obtain a round outline, however, tiny brick wedges were placed between them.

According to written sources, as early as in 1300 the municipal bath (located near present-day Brzozowa Street) was supplied with water from the River Parsęta using a wooden water pipe. The same solution was used to supply water to another bath which functioned in the 15<sup>th</sup> century and was situated in present-day Gierczak street<sup>11</sup>. In the 15<sup>th</sup> century a water pipe was constructed which supplied water from the Maćkowy Pond. This water body (non-existent today) was located near the Lęborskie Outskirt on the

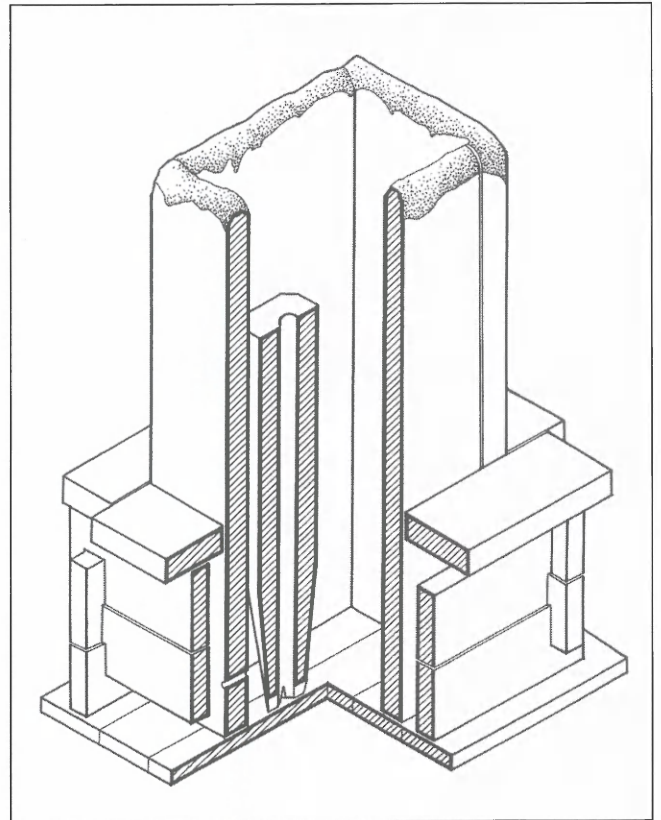

Fig. 2. Kołobrzeg, the Holy Spirit Hospital. Reconstruction of the dug-out well. Drawing Z. Polak.

eastern side of the town, in front of the Kamienna Gate. No mentions in written sources remained, based on which it could be attempted at reconstructing the spatial layout of the water pipe. It is possible, however, to suggest that the principal main was led to the town through the Stone Gate. Natural decline of the terrain enabled the water to flow based on the gravitation principle. In spite of poor quality of water, which was permanently contaminated with organic waste<sup>12</sup>, this water pipe was in use until the second half of the 17<sup>th</sup> century.

In the course of past examinations medieval waterworks installations were discovered in the plots in 7 Giełdowa street, 14, 16-17 and 36 Narutowicza street, and 4 Gierczak street (Fig. 1). It cannot be excluded that a water conduit which was discovered in the plot of 7 Giełdowa street (in the north-eastern quarter of the town, at the level of the Stone Gate) is part of the main of the system which had its intake in the Maćkowy Pond. A 25 m long section of the canal was exposed. It turned out that it slightly declined (10 cm at the distance of 25 m) towards Giełdowa street. This conduit was in use for a long time. This can be said based on traces of numerous repairs and the fact that one of damaged sections was replaced with a pipe made of a hollowed tree trunk. The oldest parts of the conduit were made of

<sup>8</sup> Both wells and latrines were situated in the backyards of plots and both types of structures were usually of a very similar construction. This is why in many cases it is impossible to distinguish between the two. It must also be remembered that wells were very often used as latrines after they had become silted up. For more detail see C. Buško, *Urządzenia wodno-kanalizacyjne w średniowiecznych i renesansowych miastach śląskich*, „Archaeologia Historica Polona”, Toruń, 1996, vol. 3, p. 94; see also Z. Polak, *Budownictwo i architektura*, [in:] *Archeologia średniowiecznego Kołobrzegu*, vol. 2, ed. M. Rębkowski, Kołobrzeg 1997, p. 152.

<sup>9</sup> B. Wywrot-Wyszkowska, Z. Polak, M. Rębkowski, *Źródła archeologiczne*, [in:] *Archeologia średniowiecznego Kołobrzegu*, vol. 5, ed. M. Rębkowski, Kołobrzeg 2010, p. 40, fig. II-20.

<sup>10</sup> B. Wywrot-Wyszkowska, *Średniowieczne i wczesnonożyczne...*, pp. 77-78.

<sup>11</sup> H. Riemann, *Geschichte der Stadt...*, pp. 49, 53; H. Göbel, *Die städtebauliche Entwicklung von Kolberg*, Düsseldorf 1928, p. 14.

<sup>12</sup> H. Riemann, *op. cit.*, p. 53; H. Göbel, *Die städtebauliche...*, p. 14.; J. Kłoskowski, *Studnie i wodociągi...*, p. 107.



Fig. 3. Kołobrzeg, Plot 21 Rynek street. Remains of the modern period water conduit and the well with brick lining.  
Photo by B. Wywrot-Wyszkowska.

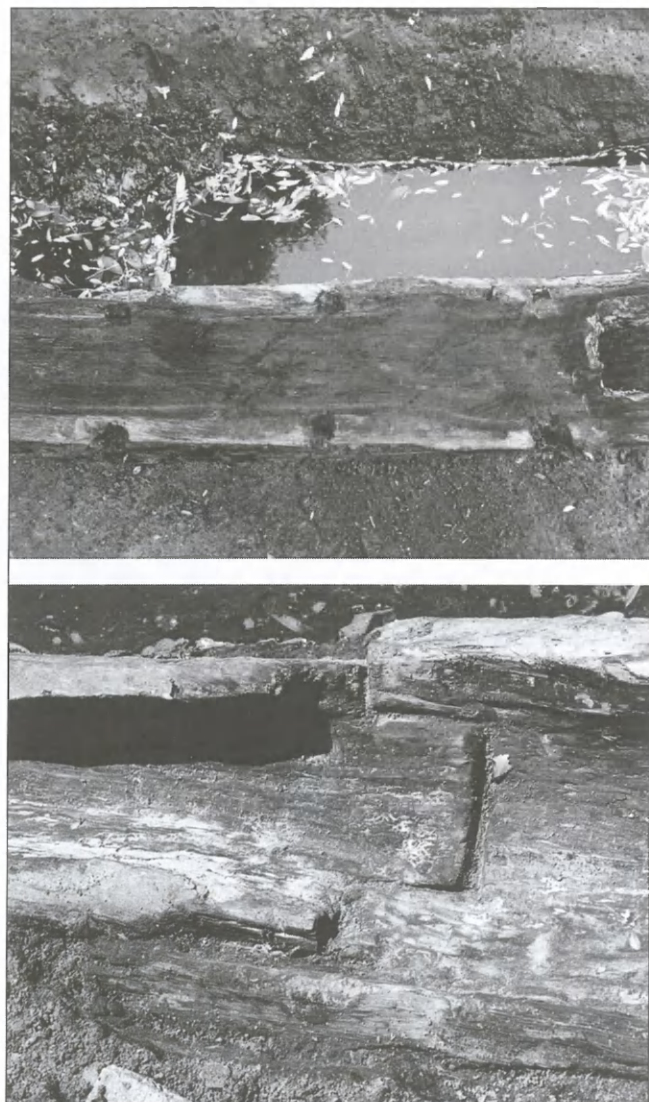

Fig. 4. Kołobrzeg, Plot 7 Gieldowa street. Fragment of the cover (top) and the canal (bottom) of the late medieval water conduit.  
Photo by Z. Polak.

beams of rectangular cross-section. 14 cm wide and 10 cm deep grooves were carved in these beams. These elements were ended with rectangular tenons which were fitted into proper mortises in the adjacent parts. Joints were caulked with moss. A cover was made of thick planks fastened with wooden pegs (Fig. 4). It seems highly probable that another main was led from the afore-mentioned canal, using the natural decline of the terrain. This main went towards the Market Square, where it divided into branches<sup>13</sup>.

A rectangular water well was discovered in the basement of the house in the plot of 5 Armii Krajowej street. A rectangular hole was situated in the western wall of the well. The hole originally contained an inlet of a canal which supplied water to the plot. A conduit made of pine edged timber (23 x 17 cm) went from the eastern wall of the well.

A 18 cm wide and 8 cm deep canal was grooved in the timber; the canal itself was covered with a thick plank. The canal went through the entire length of the house and it supplied water to another reservoir. It was a dug-in barrel, situated at the rear wall of the house (Fig. 5)<sup>14</sup>. Waterworks in the plot at 14 Narutowicza street were laid out in a similar way.

It must be stressed that waterworks found in plots at 5 Armii Krajowej street, 14, 16-17 and 36 Narutowicza street, as well as 4 Gierczak street were constructed in the second half of the 14<sup>th</sup> century. These are therefore earlier than the 15<sup>th</sup> century water pipe which supplied water from the Maćkowy Pond and which was mentioned in written sources. It is unknown, however, whether the waterworks discovered in the afore-mentioned plots were joint

<sup>13</sup> B. Wywrot-Wyszkowska, *Średniowieczne i wczesnonowożytne...*, p. 95.

<sup>14</sup> B. Wywrot-Wyszkowska, Z. Polak, M. Rębkowski, *Źródła archeologiczne*, [in:] *Archeologia średniowiecznego Kołobrzegu*, vol. 4, ed. M. Rębkowski, Kołobrzeg 1999, pp. 23, 32.



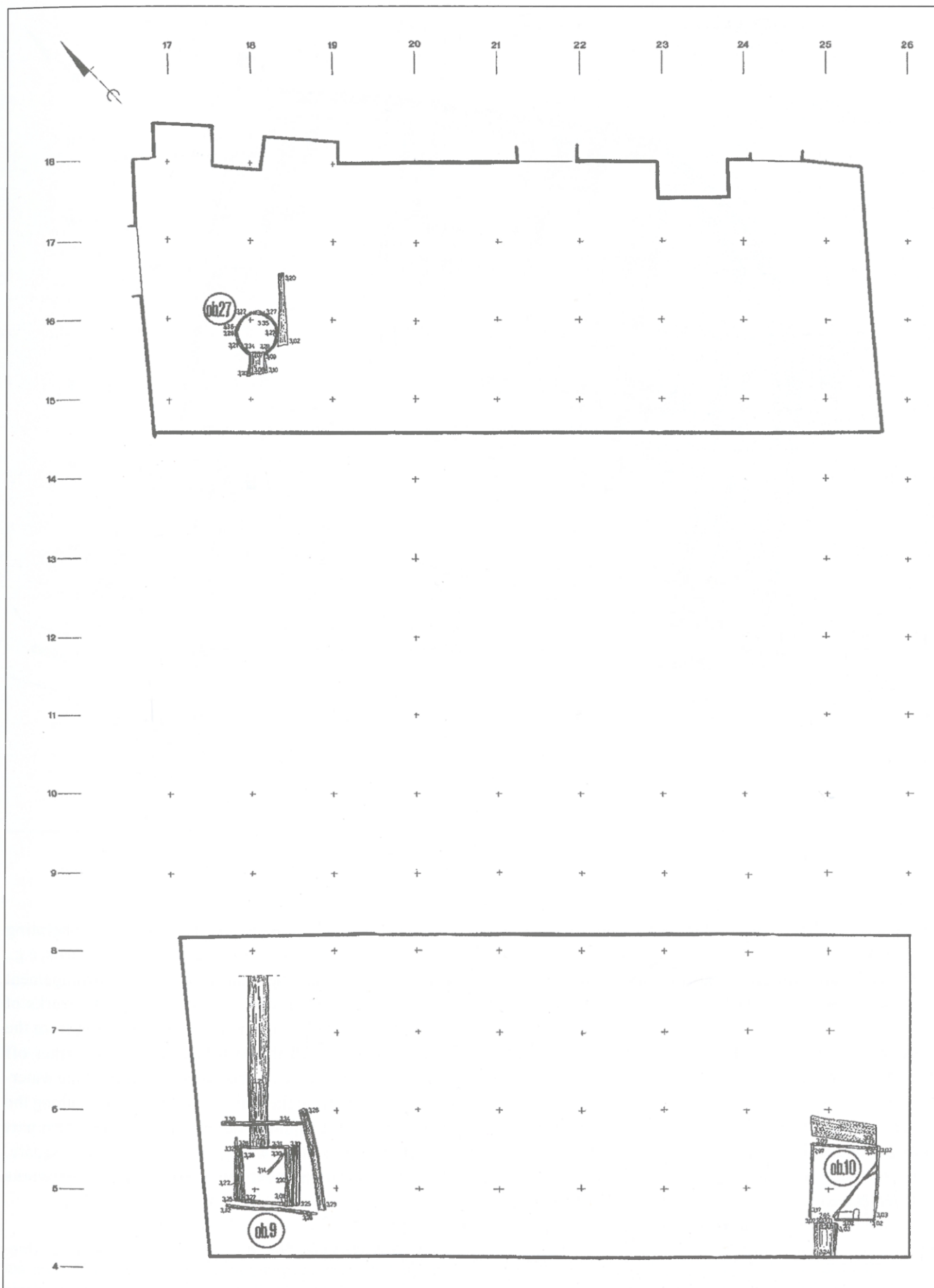

Fig. 5. Kołobrzeg, Plot 5 Armii Krajowej street. Plan of medieval (Features 9 and 27) and modern period (Feature 10) waterworks. After *Archeologia średniowiecznego Kołobrzegu*, vol. 4.

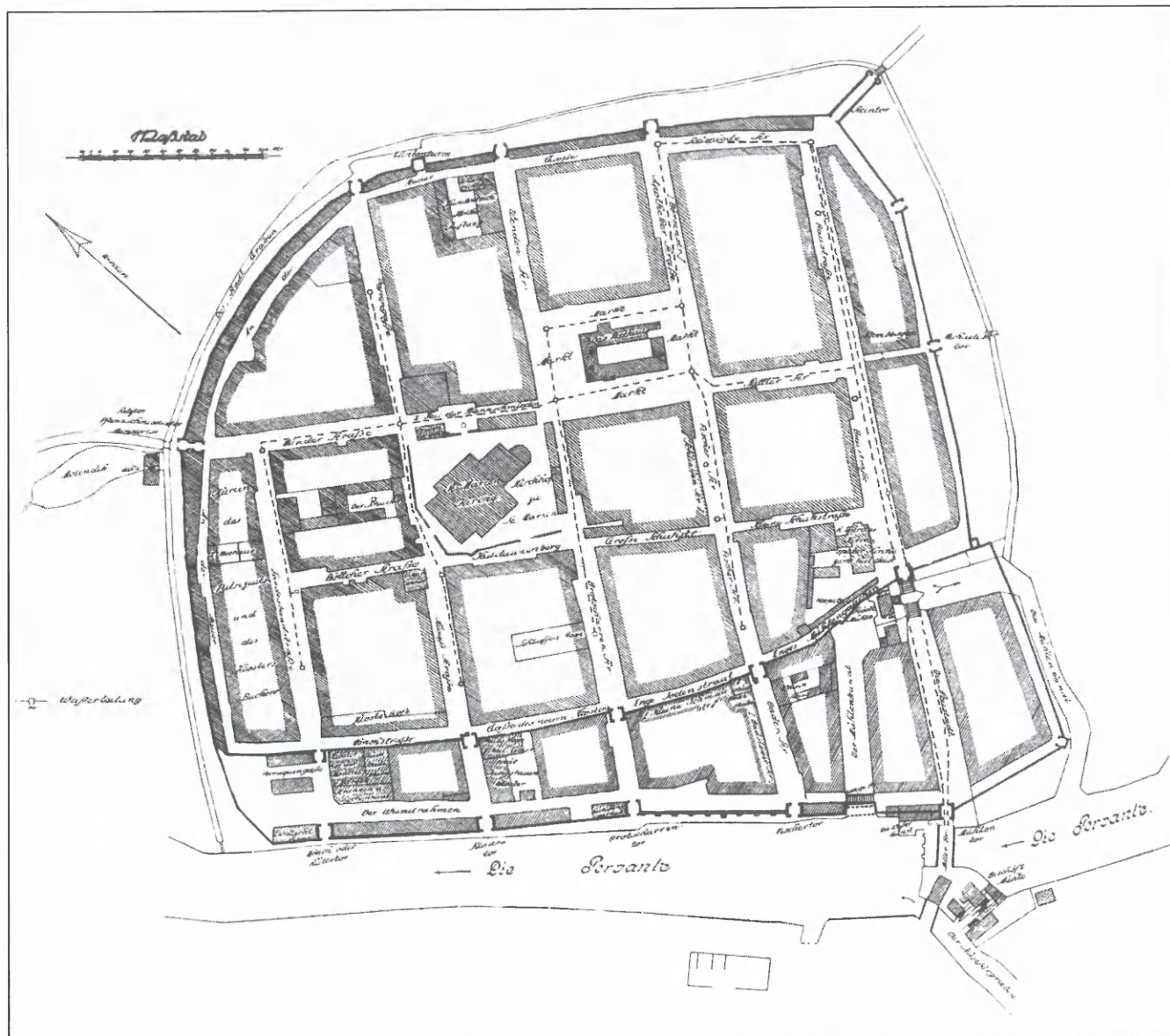

Fig. 6. Kolobrzeg. Spatial layout of the modern period (the 16th-the 18th c.) waterworks network. After H. Göbel 1928.

to one central waterworks system or to conduits in various parts of the town. Such conduits may have supplied water from local water intakes at short distances. It is noteworthy that three of the afore-mentioned plots are situated in Narutowicza street, which led to the river<sup>15</sup>. These plots, therefore, may have been joint to one water pipe which had its intake in the river.

In 1666 new municipal waterworks were built. The system was supplied with water from the River Parsęta, with an intake in front of the Mill Gate<sup>16</sup>. The intake was situated at a considerably lower level than the town. A *Wasserkunst* was therefore constructed, which pumped the water into the conduits at a proper pressure<sup>17</sup>. It is

possible that its mechanism and the principle of operating were similar to analogous installations in other towns, e.g., in Gdańsk<sup>18</sup>. Interesting data on the spatial arrangement of the waterworks network can be found in the works of Heinrich Göbl<sup>19</sup> (Fig. 6). A two-conduit main ran from the water intake through the Mill Gate and then further off along Budowlana street. Subsequent branches of the waterworks diverged from the main. One of these went along the town walls and it supplied water to the north-eastern part of the town. The other went towards the Market Square. From this location, next branches of the waterworks

<sup>18</sup> A. Hoffmann, *Die Wasserkunst der Hansestadt Danzig*, [in:] *Wasserversorgung in der Renaissancezeit*, Main am Rhein 2000, pp. 227-234; R. Krzywdziński, *Zasada działania gdańskiego Wasserkunstu w XVI-XVIII wieku*, „Kwartalnik Historii Kultury Materialnej”, vol. 56, No. 3-4, 2008, pp. 345-351.

<sup>19</sup> H. Göbel, *op. cit.*, p. 15, fig. 1.

<sup>15</sup> Cf. H. Göbel, *op. cit.*, Abb. 1.

<sup>16</sup> Cf. Riemann, *Geschichte der Stadt...*, p. 413; H. Göbel, *op. cit.*, p. 15.

<sup>17</sup> Cf. H. Göbel, *op. cit.*, p. 15.

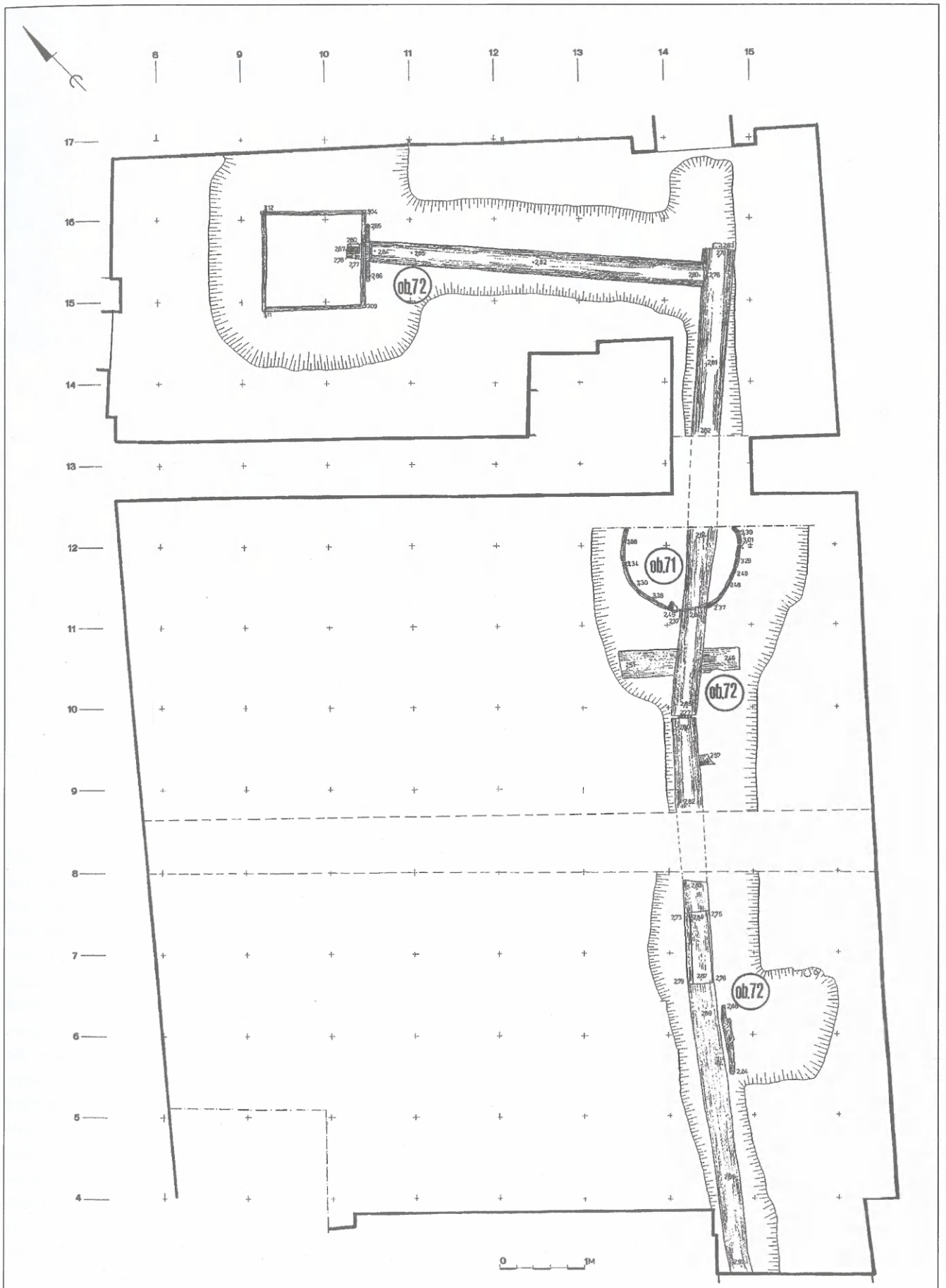

Fig. 7. Kołobrzeg, Plot 6 Armii Krajowej street. Plan of the modern period waterworks.  
 After *Archeologia średniowiecznego Kołobrzegu*, vol. 4.



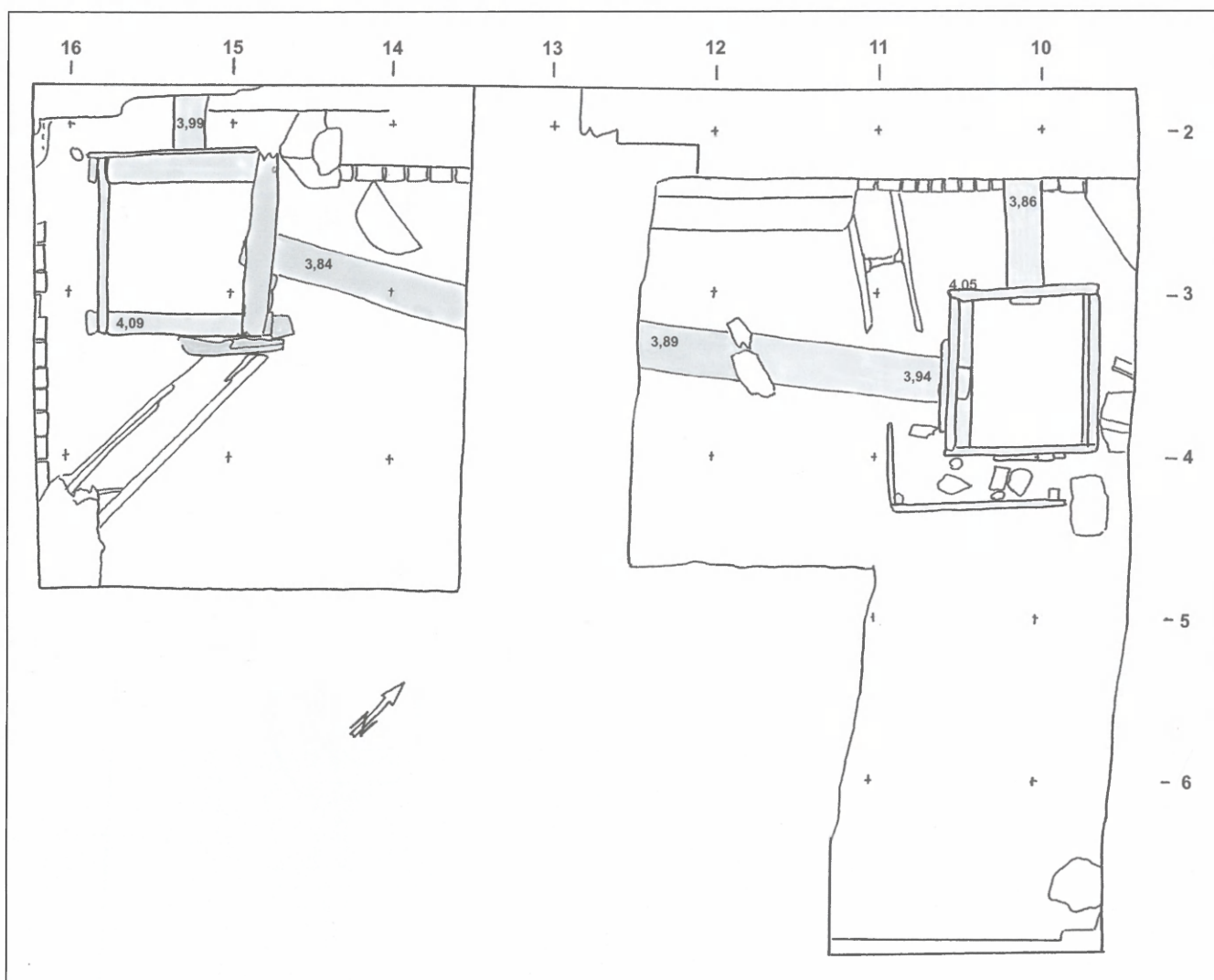

Fig. 8. Kołobrzeg, Plot 52 Gierczak street. Plan of the modern period waterworks. Drawing B. Wywrot-Wyszkowska.

diverged and they supplied water to quarters in the central, northern and south-western parts of the town. Interestingly, the location when branches diverged from the main was situated at the highest point. It could therefore be proposed that water was pumped under pressure to that location, and then it flew into the conduits based on the gravitation principle. In the course of hitherto archaeological research fragments of one of the principal mains in present-day Armii Krajowej street were exposed. Furthermore, remains of connections supplying water to a dozen of plots in the Market Square, in the streets: Ratuszowa, Armii Krajowej, Narutowicza and Gierczak (Fig. 1). Best preserved and examined installations were found in the plot of 6 Armii Krajowej street (Fig. 7). These were possibly joint to the system built in 1666. The water pipe was led to the plot by means of breaking through the foundation in the front wall. Within the building, the water conduit consisted of a course of three pipes. These were made of pine trunks with a diameter of 30-40 cm and central holes with a diameter of 8,5 cm. Pipes were joint using iron flanges shaped as bushings with ribs around them. The third section of the

conduit which led to the backyard was stopped at the end with a wooden peg. Another pipe was attached near that end using an iron bushing. The opposite end of this pipe led to a well, and its outlet was stopped with a wooden peg with a rectangular cross-section. The well was built on a rectangular plan (125 x 125 cm). Its sides were plastered with clay from outside. Its bottom was laid with planks and covered with a layer of small pebbles. On this layer a stone paving was laid. Another water conduit was discovered in the plot of 12 Armii Krajowej street. It consisted of two pipes made of hollowed pine trunks which were joint together using an iron bushing. The pipes went from the front wall to the rear part of the building, where a water reservoir was located. It was a dug-in barrel, made of oak staves which were fastened together with two bunches of metal rims. Its diameter was c. 80 cm, with the preserved height of 110 cm<sup>20</sup>. Water reservoirs were also situated by front walls of

<sup>20</sup> S. Słowiński, *Badania Kołobrzegu prowadzone przez Pracownię Archeologiczno-Konserwatorską PKZ oraz Pracownię Archeologiczną Zamku Książąt Pomorskich w Szczecinie*,





Fig. 9. Kołobrzeg, Plot 29 Narutowicza street. Fragment of the water conduit with remains of the vertically installed pump.  
Photo Z. Polak.

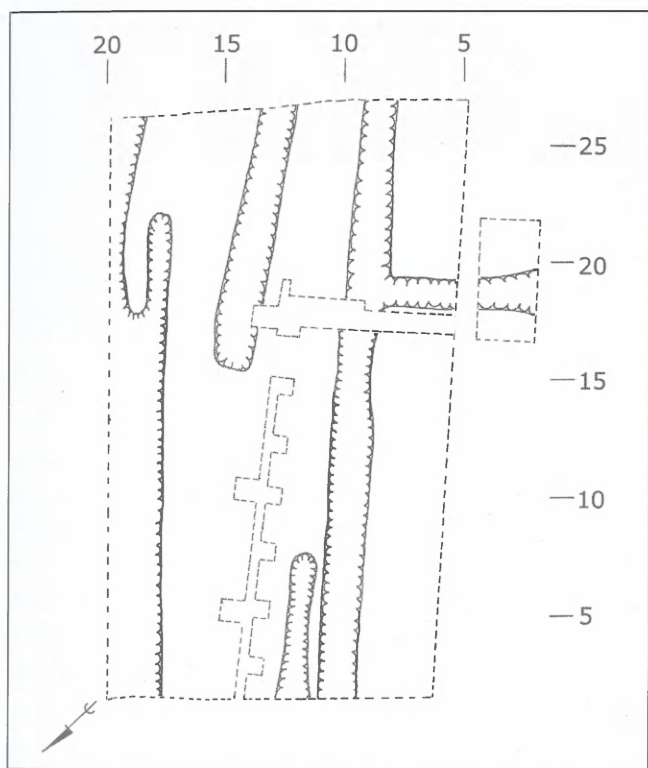

Fig. 10. Kołobrzeg, Plot Giedłowa street. Plan of drainage.  
Drawing B. Wywrot-Wyszowska.

buildings. This was the case with a small well, built on a rectangular plan (100 x 80 cm) in a house in the plot of 5 Armii Krajowej street (cf. Fig. 5). Two rectangular plan wells (102 x 94 and 110 x 110 cm respectively) were constructed in the front part of the basement of the house in the plot of 52 Gierczak street. Water was supplied to them with

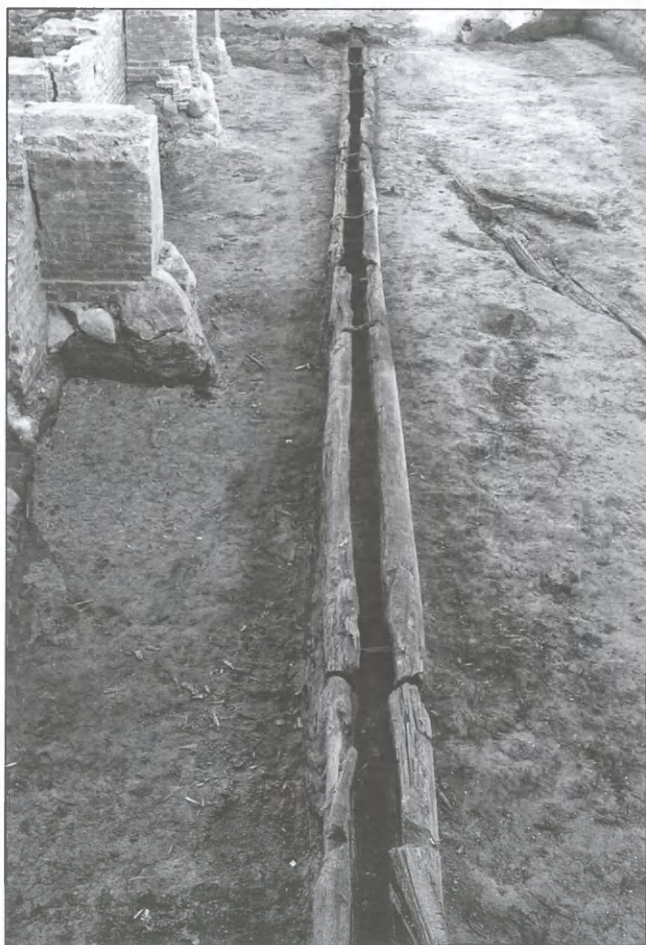

Fig. 11. Kołobrzeg, Plot 7 Giedłowa street. Drainage/sewage canal.  
Photo by Z. Polak.

separate conduits, made of rectangular beams. These were grooved in the shape of a trough and were covered with planks (Fig. 8). It was perhaps already when the connection was in use that both reservoirs were connected to each other using a pipe made of a hollowed pine trunk.

Water uptake could also be done with the use of pumps. Traces of such a device were found on a water conduit which was discovered in the plot of 29 Narutowicza street. The conduit made of hollowed pine trunks was installed in the basement of the house. Remains of a vertically fitted wooden pipe (with a diameter of 20 cm) were found on the upper surface of one of the parts of the conduit. The pipe had a centrally placed hole (with a diameter of 10 cm) which was stopped with a peg after the pipe had been removed (Fig. 9). This conduit supplied water to the surface, and it was uptaken using a pump<sup>21</sup>.

Based on these observations it can be said that dug-out wells were of the most prominent importance both in the Middle Ages and the modern period. Even after the water conduits had been made, the former were still significant

[in:] *Res et Fontes, Księga Jubileuszowa dr. Eugeniusza Cnotliwego*, eds. T. Galiński, E. Wilgocki, Szczecin 2003, p. 402; *Kołobrzeg-Stare Miasto, gm. loco, woj. koszalińskie*, „Informator Archeologiczny. Badania 1997”, Warszawa 2006, p. 297.

<sup>21</sup> Cf. R. Krzywdziński, *Wodociągi i latryny klasztoru dominikańskiego w Gdańsku*, „Archeologia Gdańska”, vol. 1, 2006, p. 246; B. Wywrot-Wyszowska, *Średniowieczne i wczesnonowożytny...*, p. 90.

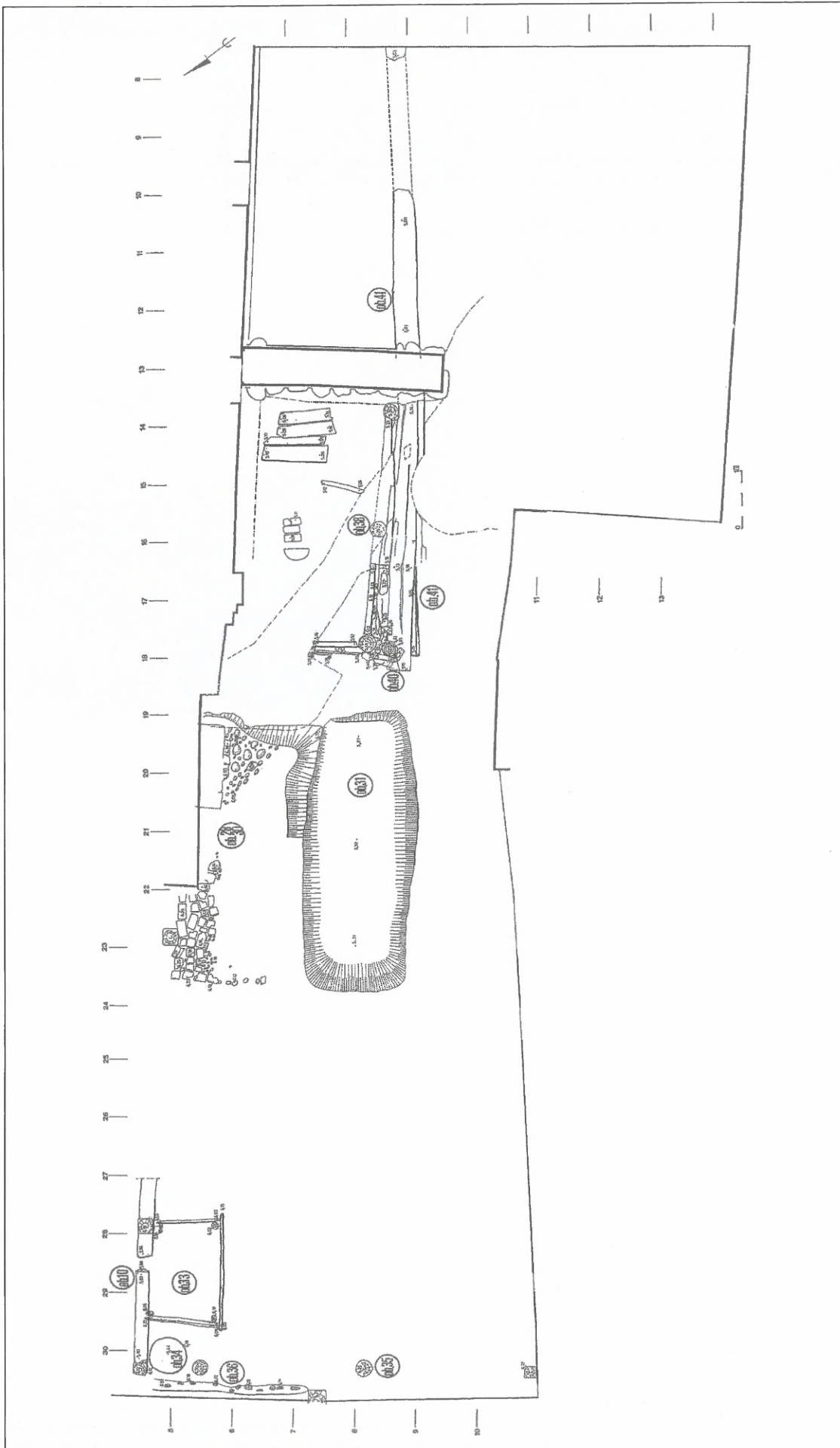

Fig. 12. Kołobrzeg, Plot 10A Ratuszowa street. Plan of the drainage canal (Feature 41), the latrine (Feature 33), and the sewage container (Feature 31). After *Archeologia średniowiecznego Kołobrzegu*, vol. 1.





Fig. 13. Kołobrzeg, Armii Krajowej street. Water circuit connection and the sewage canal. Photo by B. Wywrot-Wyszkowska.

devices used to acquire water. This is confirmed by the fact that both water conduits and wells were in use in several plots (21 Market Square, 10A Ratuszowa street, 12 Armii Krajowej street). What is more, the latter were built later than the former. It can therefore be supposed that the amount of water supplied by the conduits did not meet the demand. In order to satisfy it, additional installations were constructed<sup>22</sup>.

As early as in the second half of the 14<sup>th</sup> century water conduit systems functioned in Kołobrzeg, supplying water not only to public buildings (baths) but also to private plots. These systems were in all probability small-scale installations, which serviced only selected areas of the town. Such local systems existed in the northern (the area of present-day Armii Krajowej street near its northern part) and the south-western (the area of present-day Narutowicza street) quarter of the town. These systems may have been supplied with water from the town moat or the river<sup>23</sup>. As it can be

concluded from hitherto observations, a system of water installation within a parcel consisted of a water supplying canal and one or some connected reservoirs.

The waterworks network from the second half of the 17<sup>th</sup> century encompassed almost the entire town area within the town walls. Modern period water conduit installations were usually constructed using pipes made of hollowed tree trunks. Such pipes were more durable and tight, as opposed to canals with covers. In comparison to the medieval period, the way of supplying water to particular plots did not change significantly. It was still delivered using wooden conduits with specially built plank wells or large stave reservoirs at their outlets. Using pumps to uptake water (in the 17<sup>th</sup> century at the latest) can perhaps be considered as a sort of innovation.

#### **Disposal of the surplus of water**

Kołobrzeg was located in the marshy terrain which was difficult to properly maintain and required constant drainage. This forced people to undertake various activities aimed at dewatering the inhabited area. In the initial phase of existence of the location town, drainage works had been undertaken before any permanent buildings were constructed. These works in digging drains within inhabited

<sup>22</sup> B. Wywrot-Wyszkowska, *Średniowieczne i wczesnonowożytność...*, p. 94.

<sup>23</sup> M. Rębkowski, *The Infrastructure...*, p. 413; B. Wywrot-Wyszkowska, *Średniowieczne i wczesnonowożytność...*, p. 94.

plots<sup>24</sup>. Such structures were exposed in numerous areas of the town, situated both at the higher and lower levels of the moraine hill. These structures were trenches with trough-like or (less commonly) trapezoid cross-sections. Their length varied between 2,5 and over 25 m, with their width being 0,7-1,9 m. They were 0,4-0,6 m or even up to 1 m deep. Their walls and bottoms were usually lined with fascine. Their fills generally consisted of tiny twigs and sticks and other organic material, perhaps straw or cane. These trenches were then filled with sand<sup>25</sup>. Drains were always oriented in accordance with the lines of division of the urban space, i.e., in parallel or perpendicular to boundaries of parcels and blocks of buildings<sup>26</sup>. In some cases one drain was installed in perpendicular to the street (e.g., the plots of 12 Ratuszowa street, 36 Giełdowa street). Most commonly, however, several drain trenches were dug (e.g., the plots of 2B Market Square, 5B, 6 and 7 Armii Krajowej street, 6 and 7 Giełdowa street). These went either in parallel or in perpendicular to streets and could be connected to each other. Drainage systems could also encompass two neighbouring plots, as it was the case with the plots of 5 and 6 Giełdowa street (Fig. 10). Drains with no casings and covers could function properly in areas which were rather not built-up. One should therefore treat such features as installations used to prepare the terrain for settlement<sup>27</sup>.

Later on, alongside with the intensification of building activity, other kinds of drains were in use. Dug-in barrels were both the simplest and very popular installations. Holes were bored in the staves or bottoms were removed. Water which was soaking into the barrels needed to be manually removed from time to time. Such barrels were installed both at the lowest levels of buildings and outside them, in various parts of plots. Such containers were also part of more developed systems, where they functioned as collectors<sup>28</sup>.

In the 14<sup>th</sup> century wooden canals were commonly used for draining the soil. These were placed in trenches and were covered with soil. A very well preserved installation of that kind was discovered in the plot of 7 Giełdowa street. The feature went through the entire length of the plot and drained the water towards the street. The canal

was made of halved pine trunks. Two elements placed with the flat side inside constituted the sides of the canal. The third one functioned as a cover (Fig. 11). Contents of layers within the feature suggest that it initially served exclusively to drain the surplus of water. In the course of time, it was also used to drain sewage. Relatively broad pine (less commonly – oak) planks were also used to construct drain canals. Such canals were discovered in several plots (e.g., 10A Ratuszowa street, 11 Katedralna street, 5B, 6 and 7 Armii Krajowej street, 36, 37 and 52 Gierczak street). They had a shape of bottomless gutters made of two parallel planks placed on their edges and provided with a cover. A feature from the plot of 10A Ratuszowa street is one of better preserved devices of this kind. A 8 m long section of this canal was exposed. The installation went from the central part of the backyard of the plot and went further towards Ratuszowa street (Fig. 12). Walls of the canal were made of secondarily used planks. These were placed on their edges and were stretched using bricks which were analogously placed. A cover was made of c. 60 cm wide planks<sup>29</sup>. A similar canal was discovered in the plot of 11 Katedralna street. It was constructed using thick rough 19-20 cm wide boards with a roughly triangular cross-section. These were also placed on their edges at a distance of 25 cm from one another and were fastened with pegs inside the canal<sup>30</sup>. Only a 2,5 m long section this canal was exposed. It was therefore impossible to determine whether it went towards the street or it drained water (and possibly sewage) to a collector in the plot. A dug-in barrel may have been such a collector.

A canal in the plot of 36 Narutowicza street was remarkable due to its different construction. It was made of carefully joint oak edged timbers which were grooved in the shape of a trough. The diameter of the timbers was 25 x 50 cm and the water trough was 16 cm wide and c. 10 cm deep. Rotten planks lay in parallel to the canal, covering it partially<sup>31</sup>. It is unknown, however, whether the canal was entirely covered. It must be added that beams grooved in the shape of a trough were also used for water conduits in late medieval Kołobrzeg<sup>32</sup>. The function, however, of the installation in question is determined by the decline of the level of its bottom towards the street. It was no doubt a drain or a sewage canal.

<sup>24</sup> M. Rębkowski, *Kołobrzeg jako modelowy przykład przemian urbanizacyjnych na Pomorzu w XIII wieku*, [in:] *Civitas Cholbergiensis. Transformacja kulturowa w strefie nadbałtyckiej w XIII w.*, eds. L. Leciejewicz, M. Rębkowski, Kołobrzeg 2005, p. 50.

<sup>25</sup> B. Wywrot-Wyszowska, *Urządzenia odwadniające i sanitarne w późnośredniowiecznym Kołobrzegu*, [in:] *Kołobrzeg i okolice przez wieki*, ed. R. Ptaszyński, Kołobrzeg 2010, p. 72.

<sup>26</sup> M. Rębkowski, *Kołobrzeg jako modelowy...*, p. 50.

<sup>27</sup> Z. Polak, *Zabudowa mieszkalna i gospodarcza. Typy konstrukcji, przemiany przestrzenne, datowanie*, [in:] *Archeologia średniowiecznego Kołobrzegu*, vol. 4, ed. M. Rębkowski, Kołobrzeg 1999, p. 73, fig. II-16.

<sup>28</sup> Ibidem, see also B. Wywrot-Wyszowska, *Urządzenia odwadniające...*, p. 72-73.

<sup>29</sup> M. Rębkowski, Z. Polak, B. Wywrot, *Posesja Ratuszowa 10A*, [in:] *Archeologia średniowiecznego Kołobrzegu*, vol. 1, ed. M. Rębkowski, Kołobrzeg 1996, p. 93.

<sup>30</sup> B. Wywrot-Wyszowska, Z. Polak, M. Rębkowski, *Źródła archeologiczne*, [in:] *Archeologia średniowiecznego Kołobrzegu*, vol. 4, ed. M. Rębkowski, Kołobrzeg 1999, p. 110, fig. II-7, photo II-5.

<sup>31</sup> M. Rębkowski, Z. Polak, B. Wywrot, *Działka G. Narutowicza 36*, [in:] *Archeologia średniowiecznego Kołobrzegu*, vol. 2, ed. M. Rębkowski, Kołobrzeg 1997, p. 39, fig. II-7, photo II-6.

<sup>32</sup> B. Wywrot-Wyszowska, *Średniowieczne i wczesnonowożytne...*, p. 80-85.



A canal installed in the basement of the house at 7 Armii Krajowej street went through the entire length of the building. In its frontal part walls of the canal were made of planks placed on their edges, either in a vertical or diagonal manner. These were stretched with horizontal perches. Both its depth and width were 25-30 cm and its bottom slightly declined towards the street. The canal was shaped as a trough and it went outside through a hole in the foundation of the front wall. The canal had no cover at the time of discovery, but it cannot be excluded that it was originally covered with longitudinally placed planks<sup>33</sup>. A layer of grey sand accumulated inside the canal. It contained numerous organic insertions, sherds of clay vessels, leather scraps and animal bones. Apart from its function as a drain, in all probability the installation also served as a sewage canal. This may additionally be supported by its trough-like shape. Interestingly, similar shapes were noted in the case of a sewage canal in the plot of 9 Ratuszowa street in Kołobrzeg<sup>34</sup>, as well as gutters in Kiełbaśnicza street<sup>35</sup> and in the plot of 18 Igielna street in Wrocław<sup>36</sup>.

Based on these observations it could be proposed that drainage canals could also serve as sewage canals. This is implied by construction features of such installations (e.g., the trough-like shape, as in the case of the devices from the plots of 7 Armii Krajowej street and 36 Naturowicza street), or slime fills with a great amount of decomposed organic debris (the canal from the plots of 7 Giełdowa street and 11 Katedralna street). Such a double function may have also been fulfilled by a canal discovered in the plot of 10A Ratuszowa street.

Hitherto research on drainage installations in Kołobrzeg have demonstrated that water from the plots was drained directly to the street. Zbigniew Polak says that a dug-in collector must have run along each frontage<sup>37</sup>. Results of rescue archaeological excavations in Armii

Krajowej street seem therefore most interesting with regard to that. A fragment of a water conduit connection was discovered near Plot No. 8. The connection went in perpendicular to the street axis over a canal. The latter was constructed of an oak beam grooved in the trough-like shape and of a cover (Fig. 13). Interestingly, a 60 cm wide nest-shaped socket was made within the lower flat of the water conduit. The width of the socket corresponded to the width of the canal which went under the conduit. In all probability the socket enabled the water conduit to be led in a collision-free manner. These remarks imply that when the water conduit connection was installed, the constructors intended not to damage the other circuit which was situated at the same place and which was perhaps still in use. It is therefore possible that the water conduit which was discovered below was in fact part of a canal running within the street. The canal drained the surplus of water and possibly also sewage from the adjacent plots. This interpretation is additionally supported by the fact that the cover of this putative gutter (within the section available for observation) was in no way attached to its lower part. This usually did not occur in the case of water circuits. Attention is furthermore drawn to a considerable width (c. 24 cm) of the water trough. It cannot be excluded that the surplus of water (and perhaps also fluid sewage) were drained away to the river or the moat using this collector.

The inhabitants of Kołobrzeg were constructing drainage canals and gutters in order to improve their living conditions. This was also the case with other late medieval towns. In all probability, such activities did not eliminate all the shortcomings resulting from the constant flow of ground water. They nevertheless enabled the inhabitants to somehow minimise the negative impacts of these phenomena.

<sup>33</sup> B. Wywrot-Wyszkowska, Z. Polak, M. Rębkowski, *Źródła archeologiczne*, [in:] *Archeologia średniowiecznego Kołobrzegu*, vol. 4, ed. M. Rębkowski, Kołobrzeg 1999, p. 170.

<sup>34</sup> M. Rębkowski, Z. Polak, B. Wywrot, *Działka Ratuszowa 9*, [in:] *Archeologia średniowiecznego Kołobrzegu*, vol. 1, ed. M. Rębkowski, Kołobrzeg 1996, p. 59.

<sup>35</sup> J. Piekalski, *Elementy infrastruktury średniowiecznego Wrocławia*, [in:] *Wrocław na przełomie średniowiecza i czasów nowożytnych. Materialne przejawy życia codziennego*, *Wratislavia Antiqua*, vol. 6, eds. J. Piekalski, K. Wachowski, Wrocław 2004, p. 19, fig. 14.

<sup>36</sup> P. Guszpit, A. Wiśniewski, *Działka mieszcząca Rynek 50 – Igielna 18. Przemiany osadnicze w świetle nawarstwień kulturowych*, [in:] *Rynek wrocławski w świetle badań archeologicznych*, Part II, *Wratislavia Antiqua*, vol. 5, ed. J. Piekalski, Wrocław 2002, p. 201.

<sup>37</sup> Z. Polak, *Zabudowa mieszkalna...*, p. 182.

### Streszczenie

#### **Zaopatrzenie w wodę oraz odprowadzanie jej nadmiaru w średniowiecznym i wczesnonowożytnym Kołobrzegu.**

W trakcie badań wykopaliskowych prowadzonych na terenie późnośredniowiecznego Kołobrzegu pozyskano liczne i zróżnicowane źródła, w tym również umożliwiające zilustrowanie gospodarki wodnej. Mieszkańcy Kołobrzegu mogli zaopatrywać się w wodę z trzech źródeł, mianowicie z rzeki lub fosy miejskiej, z pobliskich stawów i strumieni, a także wykorzystywać wody gruntowe. Woda dostarczana była do miasta wykonanymi z drewna wodociągami

ciśnieniowo-grawitacyjnymi. Budowano również publiczne i prywatne studnie głębinowe, pierwotnie drewniane, a od XVII wieku coraz częściej ceglane. Wzniesiony w średniowieczu, a później dość często modernizowany, system urządzeń zaopatrujących mieszkańców w wodę oraz odprowadzających jej nadmiar przetrwał aż do końca XIX stulecia, kiedy zbudowano w Kołobrzegu nowoczesną sieć wodociągową.