

**Modern Approaches in Fuzzy Sets,  
Intuitionistic Fuzzy Sets,  
Generalized Nets and Related Topics  
Volume II: Applications**

**Editors**

**Krassimir T. Atanassov  
Władysław Homenda  
Olgierd Hryniewicz  
Janusz Kacprzyk  
Maciej Krawczak  
Zbigniew Nahorski  
Eulalia Szmidt  
Sławomir Zadrozny**

**SRI PAS**



**IBS PAN**





**Systems Research Institute  
Polish Academy of Sciences**

**Modern Approaches in Fuzzy Sets,  
Intuitionistic Fuzzy Sets,  
Generalized Nets and Related Topics.  
Volume II: Applications**

**Editors**

**Krassimir Atanassov  
Władysław Homenda  
Olgierd Hryniewicz  
Janusz Kacprzyk  
Maciej Krawczak  
Zbigniew Nahorski  
Eulalia Szmidt  
Sławomir Zadrozny**



© **Copyright by Systems Research Institute  
Polish Academy of Sciences  
Warsaw 2014**

All rights reserved. No part of this publication may be reproduced, stored in retrieval system or transmitted in any form, or by any means, electronic, mechanical, photocopying, recording or otherwise, without permission in writing from publisher.

Systems Research Institute  
Polish Academy of Sciences  
Newelska 6, 01-447 Warsaw, Poland  
[www.ibspan.waw.pl](http://www.ibspan.waw.pl)

**ISBN 83-894-7554-5**



# Generalized net model of the upper limb withdrawal reflex

**Simeon Ribagin<sup>1</sup>, Vihren Chakarov<sup>2</sup>  
and Krassimir Atanassov<sup>3</sup>**

<sup>1</sup> Institute of Biophysics and Biomedical Engineering,  
Bulgarian Academy of Sciences  
105 Acad. G. Bonchev Str., 1113 Sofia, Bulgaria  
sim\_ribagin@mail.bg

<sup>2</sup> Institute of Biophysics and Biomedical Engineering,  
Bulgarian Academy of Sciences  
105 Acad. G. Bonchev Str., 1113 Sofia, Bulgaria  
vihren@biomed.bas.bg

<sup>3</sup> Institute of Biophysics and Biomedical Engineering,  
Bulgarian Academy of Sciences  
105 Acad. G. Bonchev Str., 1113 Sofia, Bulgaria  
krat@bas.bg

## Abstract

In a series of papers the Generalized Net (GN) models of the human body and its systems are described in general. The present paper is devoted to the GN-modelling of the withdrawal reflex observed in the upper limb. The model is constructed in a simplified form. The purpose of the present paper is to give an example of GN-modelling of an involuntary movement in the upper limb.

**Keywords:** Generalized net, Limb withdrawal reflex, Modelling.

---

*Modern Approaches in Fuzzy Sets, Intuitionistic Fuzzy Sets, Generalized Nets and Related Topics. Volume II: Applications* (K.T. Atanassov, W. Homenda, O. Hryniewicz, J. Kacprzyk, M. Krawczak, Z. Nahorski, E. Szmidt, S. Zadrozny, Eds.), IBS PAN - SRI PAS, Warsaw, 2014

# 1 Introduction

Generalized Nets (GNs, see [1, 2, 3]) are extensions of Petri nets and their modifications. During the last 30 years, they have a lot of applications in medicine and biology. In [4] GN-models of human body and of the separate systems in the human body are described. One of the modeled by GN systems are the musculo-skeletal (see [5]). The present paper is the first one that is devoted to a GN-model represents involuntary movement in the upper limb. We represent a simple reflex activity after external painful stimulus. In Section 2 we give short remarks on GNs and in Section 3 – on withdrawal reflex. Section 4 contains our GN-model.

## 2 Short remarks on generalized nets

Following [2, 3], we shall introduce the concept of a GN-transition and of a GN.

Every GN-transition is described by a seven-tuple (Fig. 1):

$$Z = \langle L', L'', t_1, t_2, r, M, \square \rangle,$$

where:

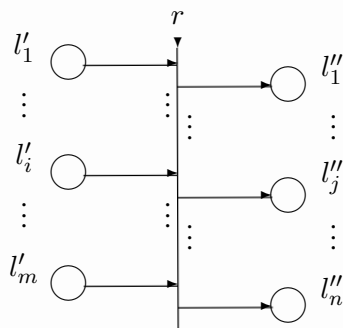

Fig. 1: GN-transition

(a)  $L'$  and  $L''$  are finite, non-empty sets of places (the transition's input and output places, respectively);

(b)  $t_1$  is the current time-moment of the transition's firing;

(c)  $t_2$  is the current value of the duration of its active state;

(d)  $r$  is the transition's *condition* determining which tokens will pass (or *transfer*) from the transition's inputs to its outputs; it has the form of an Index Matrix (IM; see [2, 3]):



$$r = \begin{array}{c|c} & l''_1 \dots l''_j \dots l''_n \\ \hline l'_1 & \\ \vdots & \\ l'_i & (r_{i,j} - \text{predicate}) \\ \vdots & \\ l'_m & \end{array} \quad ;$$

$(1 \leq i \leq m, 1 \leq j \leq n)$

$r_{i,j}$  is the predicate which corresponds to the  $i$ -th input and  $j$ -th output places. When its truth value is “true”, a token from  $i$ -th input place can be transferred to  $j$ -th output place; otherwise, this is not possible;

(e)  $M$  is an IM of the capacities of transition’s arcs:

$$M = \begin{array}{c|c} & l''_1 \dots l''_j \dots l''_n \\ \hline l'_1 & \\ \vdots & \\ l'_i & (m_{i,j} \geq 0 - \text{natural number}) \\ \vdots & \\ l'_m & \end{array} \quad ;$$

$(1 \leq i \leq m, 1 \leq j \leq n)$

(f)  $\square$  is an object having a form of a Boolean expression. It contains as variables the symbols which serve as labels for transition’s input places, and is an expression built up of variables and the Boolean connectives  $\wedge$  and  $\vee$ . When the value of a type is “true”, the transition can become active, otherwise it cannot.

The ordered four-tuple

$$E = \langle \langle A, \pi_A, \pi_L, c, f, \theta_1, \theta_2 \rangle, \langle K, \pi_K, \theta_K \rangle, \langle T, t^o, t^* \rangle, \langle X, \Phi, b \rangle \rangle$$

is called a *Generalized Net* (GN) if:

- (a)  $A$  is a set of transitions;
- (b)  $\pi_A$  is a function giving the priorities of the transitions;
- (c)  $\pi_L$  is a function giving the priorities of the places;
- (d)  $c$  is a function giving the capacities of the places;
- (e)  $f$  is a function which calculates the truth values of the predicates of the transition’s conditions;
- (f)  $\theta_1$  is a function giving the next time-moment when a given transition  $Z$  can be activated, i.e.,  $\theta_1(t) = t'$ , where  $pr_3 Z = t, t' \in [T, T + t^*]$  and  $t \leq t'$ . The

value of this function is calculated at the moment when the transition terminates its functioning;

(g)  $\theta_2$  is a function giving the duration of the active state of a given transition  $Z$ , i. e.,  $\theta_2(t) = t'$ , where  $pr_4 Z = t \in [T, T + t^*]$  and  $t' \geq 0$ . The value of this function is calculated at the moment when the transition starts functioning;

(h)  $K$  is the set of the GN's tokens;

(i)  $\pi_K$  is a function giving the priorities of the tokens;

(j)  $\theta_K$  is a function giving the time-moment when a given token can enter the net;

(k)  $T$  is the time-moment when the GN starts functioning. This moment is determined with respect to a fixed (global) time-scale;

(l)  $t^o$  is an elementary time-step, related to the fixed (global) time-scale;

(m)  $t^*$  is the duration of the GN functioning;

(n)  $X$  is the set of all initial characteristics the tokens can receive when they enter the net;

(o)  $\Phi$  is a characteristic function which assigns new characteristics to every token when it makes a transfer from an input to an output place of a given transition.

(p)  $b$  is a function giving the maximum number of characteristics a given token can receive.

A GN may lack some of the components, and such GNs give rise to special classes of GNs called *reduced GNs*. The omitted elements of the reduced GNs can be marked by “\*”.

### 3 The withdrawal reflex

The withdrawal reflex is an example of a typical reflex activity. The main feature of such activity is a prompt response of the body to a given stimulus, thus enables the organism to respond immediately to certain stimuli in the environment. A “reflex” is any response that occurs automatically without conscious effort [6]. The neuronal circuit involved in accomplishing reflex activity is known as a reflex arc. The reflex arcs typically consist of a five basic components: sensory receptor - sensory neuron/afferent pathway/ - integrating center - motor neuron/efferent pathway/ - effector.

The sensory receptors are specialized cells that translate physical energy of the stimulus into an electrical signal, a process termed “sensory transduction” [7]. The electrical signal in the receptor neurons is then translated into action potential that is relayed by the afferent pathway to the integrating center (CNS). In the integrating center, the impulse may be inhibited, transmitted or reverted, accorded

to the appropriate response. The “instructions” from the center are transmitted via efferent pathway to the effector organ. Most of the reflex arcs in the center include one or more interneurons between the sensory and motor neurons.

In most sensory receptors, the receptor potential is graded in size according to the intensity of the stimulus. A stronger stimulus produces a larger receptor potential and causes the sensory neurons to fire action potentials more frequently during the stimulus. Each kind of sensory receptor is especially sensitive to one particular form of energy or stimulus.

The withdrawal reflex is a polysynaptic basic spinal reflex respond to the noxious (painful) stimulus. An example of the withdrawal reflex is when a person touches a hot object a withdrawal reflex is initiated to pull the hand away from the object without conscious command. The neuronal circuit underlying limb withdrawal in response to a painful stimulus is very complicated and involves several peripheral and central nerve structures, which we will briefly discuss below. For simplicity we shall discuss only the local signs produced by the withdrawal reflex in a single joint (elbow joint) and only two muscles working in pairs (mm.biceps brachii - mm.triceps brachii).

In most cases the interneurons in the effected spinal segment make similar connections with all of the flexor and extensor motor neurons controlling all of the joints in the upper limb.

Painful stimulus applied on the receptive field of the hand activates cutaneous nociceptors. The nociceptors can be defined as sensory receptors that respond to stimuli that threaten or actually damage tissues. Cutaneous nociceptors may respond well to just one type of intense stimulus (mechanical, thermal or chemical), to any combination of two of these stimuli, or to all three forms of stimulus energy [9]. When a receptor is stimulated enough to reach threshold, an action potential is generated in the afferent sensory neuron. The nervous impulse travels via afferent fibers of peripheral nerves and enters through the dorsal root ganglion in the spinal cord. In the spinal cord the afferent neuron stimulates excitatory interneurons, which activates motor neurons to mm. biceps brachii (agonist). In the same time inhibitory neuron, inhibits the motor neuron to mm. triceps brachii (antagonist), thus produces an elbow flexion and pulling the hand away from the painful stimulus. This type of connection involving activation of the motor neurons to one muscle and simultaneous inhibition of the nerves to its antagonistic muscles is known as reciprocal innervation [6]. In the spinal cord the afferent signal is transmitted to other interneurons that carry the signal to the sensory areas of the brain via an ascending pathway. When the impulse reaches the brain the information can be stored as a memory. Moreover the brain can modify and override the reflex in the higher motor control center. The brain send out signals through the

descending pathways to the efferent motor neurons supplying the involved muscles (In our case mm.biceps brachii and mm.triceps brachii) to override the input from the receptors. By this conscious command from higher centers in the brain, motor neurons to mm.biceps brachii are now receiving more inhibitory (efferent) than excitatory (afferent) impulses, parallel the mm. triceps brachii receives more excitatory (efferent) than inhibitory (via the reflex arc) impulses and thus the arm is kept extended despite the external stimulus. In this way the withdrawal reflex can be voluntarily suppressed. The withdrawal reflex has a relatively long latency because the afferent pathway uses small, slowly conducting fibers and involves many synapses [8].

## **4 Generalized net model of the withdrawal reflex in the upper limb**

Here we represent a GN-model of the withdrawal reflex observed in the upper limb in relaxed position. For simplicity we will unite the peripheral and central nervous structures (spinal cord) in one transition. For the purpose of the present model we will add a separate transition which will represent the functions of the brain. The GN-model (Fig.2) has 5 transitions and 18 places with the following meaning.

- Transition  $Z_1$  represents the structures of the hand and wrist.
- Transition  $Z_2$  represents the function of the nervous system (both peripheral and central structures)
- Transition  $Z_3$  represents the function of the brain.
- Transition  $Z_4$  represents the function of the striated muscles and tendons of the arm.
- Transition  $Z_5$  represents the function of the joints and ligaments of the elbow complex.

Each of these transitions contains a special place to collect and keep information about the current status of the respective structures which it represents, as follows.

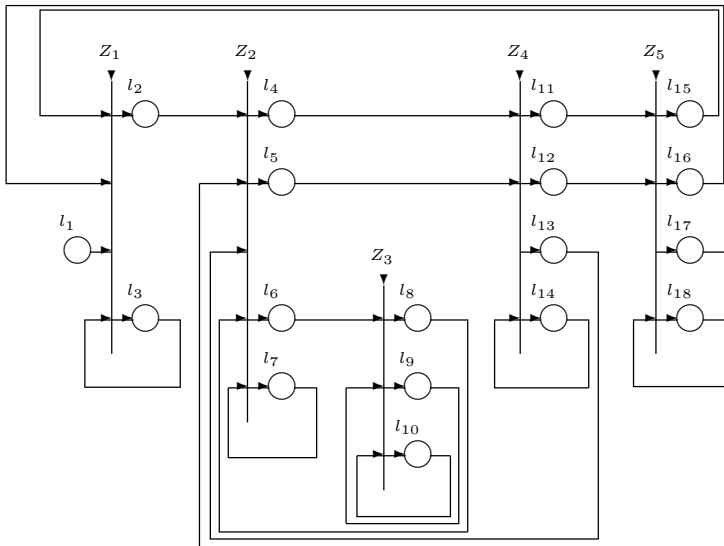

Fig. 2.

- In place  $l_3$  token  $\alpha$  stays permanently and it collects information about the current status of the hand and wrist structures.
- In place  $l_7$  token  $\beta$  collects information about the current status of the PNS and CNS (spinal cord).
- In place  $l_9$  token  $\nu$  collects information about the current status of the sensory centers in the brain .
- In place  $l_{10}$  token  $\kappa$  collects information about the current status of the higher centers in the brain.
- In place  $l_{14}$  token  $\mu$  collects information about the current status of the striated muscles and tendons of the arm.
- In place  $l_{18}$  token  $\eta$  collects information about the current status of the elbow complex.

Tokens  $\alpha, \beta, \nu, \kappa, \mu$  and  $\eta$  that permanently stay, respectively, in these places obtain as current characteristic the corresponding information. At the time of duration of the GN-functioning, some of these tokens can split, generating new tokens, that will transfer in the net obtaining respective characteristics, and also in some moments they will unite with some of tokens  $\alpha, \beta, \nu, \kappa, \mu$  and  $\eta$ . The five GN transitions have the following forms.

$$Z_1 = \langle \{l_1, l_3, l_{15}, l_{16}\}, \{l_2, l_3\}, \begin{array}{c|cc} & l_2 & l_3 \\ \hline l_1 & false & true \\ l_3 & W_{3,2} & true \\ l_{15} & false & true \\ l_{16} & false & true \end{array} \rangle,$$

where

$W_{3,2}$  = “the nociceptors, located in the free nerve endings of the  $A_\beta$  and  $C$  fibers are stimulated enough to reach threshold”.

Token  $\varepsilon$  in place  $l_1$  enters with characteristic

“external stimulus - type, intensity ,etc.”.

The tokens from the three input places enter place  $l_3$  and unite with token  $\alpha$  that obtains the above mentioned characteristic. On the other hand, when predicate  $W_{3,2}$  has a truth value “true”, token  $\alpha$  splits to two tokens, the same token  $\alpha$  and token  $\alpha_1$ , that enters place  $l_2$  and there it obtains characteristic

“afferent sensory signal to the CNS (spinal cord)”.

$$Z_2 = \langle \{l_2, l_7, l_8, l_{12}, l_{15}\}, \{l_4, l_5, l_6, l_7\}, \begin{array}{c|cccc} & l_4 & l_5 & l_6 & l_7 \\ \hline l_2 & false & false & false & true \\ l_7 & W_{7,4} & W_{7,5} & true & true \\ l_8 & false & false & false & true \\ l_{12} & false & false & false & true \\ l_{15} & false & false & false & true \end{array} \rangle,$$

where

$W_{7,4}$  = “the input from the receptors initiating the reflex”,

$W_{7,5}$  = “the brain send out conscious signals to override the reflex”.

The tokens from all input places enter place  $l_7$  and unite with token  $\beta$  that obtains the above mentioned characteristic. On the other hand, token  $\beta$  splits to four tokens, the same token  $\beta$  and tokens  $\beta_1, \beta_2$  and  $\beta_3$  that enters respectively places  $l_4, l_5$  and  $l_6$ .

When predicate  $W_{7,4}$  has a truth value “true”, a token  $\beta_1$  enters place  $l_4$  and there it obtains characteristic

“excitatory impulse to the motor units of mm.biceps brachii and inhibitory impulse to the motor units of mm.triceps brachii”.

When predicate  $W_{7,5}$  has a truth value “*true*”, a token  $\beta_2$  enters place  $l_5$  and there it obtains characteristic

“inhibitory impulse to the motor units of mm. biceps brachii and excitatory impulse to the motor units of mm. triceps brachii”.

Token  $\beta_3$  enters place  $l_6$  with characteristic

“afferent ascending signal to the brain”.

$$Z_3 = \langle \{l_6, l_9, l_{10}\}, \{l_8, l_9, l_{10}\}, \begin{array}{c|ccc} & l_8 & l_9 & l_{10} \\ \hline l_6 & false & true & false \\ l_9 & false & true & true \\ l_{10} & true & false & true \end{array} \rangle.$$

Token from place  $l_6$  enters place  $l_9$  and unites with token  $\nu$ . It splits to two tokens - itself and token  $nu_1$  that enters place  $l_{10}$  with characteristic

“sensation of pain - type, location, intensity etc.”.

In place  $l_{10}$  token  $\nu_1$  unites with token  $\kappa$ , which splits to two tokens the same token  $\kappa$  and token  $\kappa_1$  that enters place  $l_8$  with characteristic

“efferent signal from higher motor centers, to override the reflex”.

$$Z_4 = \langle \{l_4, l_5, l_{14}\}, \{l_{11}, l_{12}, l_{13}, l_{14}\}, \begin{array}{c|cccc} & l_{11} & l_{12} & l_{13} & l_{14} \\ \hline l_4 & false & false & false & true \\ l_5 & false & false & false & true \\ l_{14} & W_{14,11} & W_{14,12} & true & true \end{array} \rangle,$$

where

$W_{14,11}$  = “the excitatory impulse to mm. biceps brachii is stronger than inhibitory impulse”,

$W_{14,12}$  = “the inhibitory impulse to mm.biceps brachii is stronger than excitatory impulse”.

The tokens from all input places enter place  $l_{14}$  and unite with token  $\mu$  that obtains the above mentioned characteristic. On the other hand, token  $\mu$  splits to four tokens, the same token  $\mu$  and tokens  $\mu_1$ ,  $\mu_2$  and  $\mu_3$  that enter places  $l_{11}$ ,  $l_{12}$  and  $l_{13}$ , respectively.

When predicate  $W_{14,11}$  has a truth-value “*true*”, token  $\mu_1$  enters place  $l_{11}$  and there it obtains characteristic

“involuntary muscular activation of the mm.biceps brachii”.

When predicate  $W_{14,12}$  has a truth-value “*true*”, token  $\mu_2$  enters place  $l_{12}$  and there it obtains characteristic

“voluntary muscular activation of the mm.triceps brachii”.

Token  $\mu_3$  in place  $l_{13}$  obtains characteristic

“afferent sensory impulses from intra and extrafusul muscle fibers”.

$$Z_5 = \langle \{l_{11}, l_{12}, l_{18}\}, \{l_{15}, l_{16}, l_{17}, l_{18}\}, \begin{array}{c|cccc} & l_{15} & l_{16} & l_{17} & l_{18} \\ \hline l_{11} & false & false & false & true \\ l_{12} & false & false & false & true \\ l_{18} & W_{18,15} & W_{18,16} & true & true \end{array} \rangle,$$

where

$W_{18,15}$  = “there is a muscular activation of the mm.biceps brachii”,

$W_{18,16}$  = “there is a voluntary muscular activation of the mm. triceps brachii”.

The tokens from all input places enter place  $l_{18}$  and unite with token  $\eta$  that obtains the above mentioned characteristic. On the other hand, token  $\eta$  splits to four tokens, the same token  $\eta$  and tokens  $\eta_1, \eta_2$  and  $\eta_3$  that enter in places  $l_{15}, l_{16}$  and  $l_{17}$ , respectively.

When predicate  $W_{18,15}$  has a truth-value “*true*”, token  $\eta_1$  enters place  $l_{15}$  and there it obtains characteristic

“flexion in the elbow”.

When predicate  $W_{18,16}$  has a truth-value “*true*” token  $\eta_2$  enters place  $l_{16}$  and there it obtains characteristic

“the elbow remains extended (the withdrawal reflex has been voluntary overridden)”.

Token  $\eta_3$  in place  $l_{17}$  take on the characteristic

“afferent (sensory) impulse from the structures of the elbow complex”.



## 5 Conclusion

GN model constructed in that way is the first step to building a detailed GN- model describing the overall function of the upper limb with the relations among the upper limb structures. The model can be complicated and detailed, with including of more muscle groups acting in the elbow complex. The future models will include the presence of voluntary movements, different types of pathology and rehabilitation treatments.

## Acknowledgements

*This work is supported by National Science Fund of Bulgaria by grant DID-02-29 "Modelling Processes with Fixed Development Rules (ModProFix)".*

## References

- [1] Alexieva, J., E. Choy, E. Koycheva. Review and bibliography on generalized nets theory and applications. In:- A Survey of Generalized Nets (E. Choy, M. Krawczak, A. Shannon and E. Szmidt, Eds.), Raffles KvB Monograph, No. 10, 2007, 207-301.
- [2] K. Atanassov, Generalized Nets. Singapore, World Scientific, 1991.
- [3] K. Atanassov, On Generalized Nets Theory. Sofia, "Prof. M. Drinov" Acad. Publ. House, 2007.
- [4] K. Atanassov, V. Chakarov, A. Shannon, J. Sorsich, Generalized Net Models of the Human Body, Sofia, "Prof. M. Drinov" Acad. Pub. House, 2008.
- [5] V. Chakarov, K. Atanassov, A. Shannon. Generalized net model of the human muscular-skeletal system. A Survey of Generalized Nets (E.Y.H. Choy, M. Krawczak, A. Shannon, E. Szmidt, Eds.), Raffles KvB Monograph No. 10, Sydney, 2007, 127-140.
- [6] L. Sherwood, Human Physiology: From Cells to Systems, 8th edition, Cengage Learning Custom Publishing, 2012, pp.179-180.
- [7] G.G. Matthews, Neurobiology: Molecules, Cells and Systems, 2nd edition, Wiley-Blackwell, 2001, p.284.
- [8] J. Bullock, J. Boyle, M.B. Wang, NMS Physiology, Lippincott Williams and Wilkins, 4th edition, 2001, p.94.

- [9] D. William, Jr. Richard, E. Coggeshall, *Sensory Mechanisms of the Spinal Cord: Primary Afferent Neurons an the Spinal Dorsal Horn*, 3th edition, Springer, 2004, p.50.



**The papers presented in this Volume 2 constitute a collection of contributions, both of a foundational and applied type, by both well-known experts and young researchers in various fields of broadly perceived intelligent systems.**

**It may be viewed as a result of fruitful discussions held during the Twelfth International Workshop on Intuitionistic Fuzzy Sets and Generalized Nets (IWIFSGN-2013) organized in Warsaw on October 11, 2013 by the Systems Research Institute, Polish Academy of Sciences, in Warsaw, Poland, Institute of Biophysics and Biomedical Engineering, Bulgarian Academy of Sciences in Sofia, Bulgaria, and WIT - Warsaw School of Information Technology in Warsaw, Poland, and co-organized by: the Matej Bel University, Banska Bystrica, Slovakia, Universidad Publica de Navarra, Pamplona, Spain, Universidade de Tras-Os-Montes e Alto Douro, Vila Real, Portugal, Prof. Asen Zlatarov University, Burgas, Bulgaria, and the University of Westminster, Harrow, UK:**

**[Http://www.ibspan.waw.pl/ifs2013](http://www.ibspan.waw.pl/ifs2013)**

**The consecutive International Workshops on Intuitionistic Fuzzy Sets and Generalized Nets (IWIFSGNs) have been meant to provide a forum for the presentation of new results and for scientific discussion on new developments in foundations and applications of intuitionistic fuzzy sets and generalized nets pioneered by Professor Krassimir T. Atanassov. Other topics related to broadly perceived representation and processing of uncertain and imprecise information and intelligent systems have also been included. The Twelfth International Workshop on Intuitionistic Fuzzy Sets and Generalized Nets (IWIFSGN-2013) is a continuation of this undertaking, and provides many new ideas and results in the areas concerned.**

**We hope that a collection of main contributions presented at the Workshop, completed with many papers by leading experts who have not been able to participate, will provide a source of much needed information on recent trends in the topics considered.**

ISBN 838947554-5



9 788389 475541