

Stability problem of a conical shell with a variable wall thickness subjected to torsion

T. GAŁKIEWICZ (ŁÓDŹ)

THE PAPER is dealing with the stability problem of a conical shell with a linear variable wall thickness ($h = \mu s$) and simply supported edges, subjected to torsion. The elaboration is valid for conical shells with a moderate apex angle. The expression for the deflection of the shell is shown in the formula (1). By solving of the problem, Ritz approximate method was used. It is shown that by applying relatively simple formulae obtained by the author, the upper critical stress (3), and the number of arising on the circumference waves (2) may be determined.

THE AIM of this paper is to find an approximate solution of the linear problem of stability of a conical shell with linearly variable wall thickness subject to a torque M_0 . The shell considered is orthotropic and has a moderately large vertex angle. The wall thickness is assumed to increase proportionally to the distance s measured from the vertex. The solution is obtained by means of the Ritz method.

1. Notations

- s_1, s_2, L, R_1, R_2 dimensions shown in Fig. 1,
- α the angle between the generators and the plane perpendicular to the axis,
- s, φ coordinates defining the position of an arbitrary point of the middle surface of the shell,

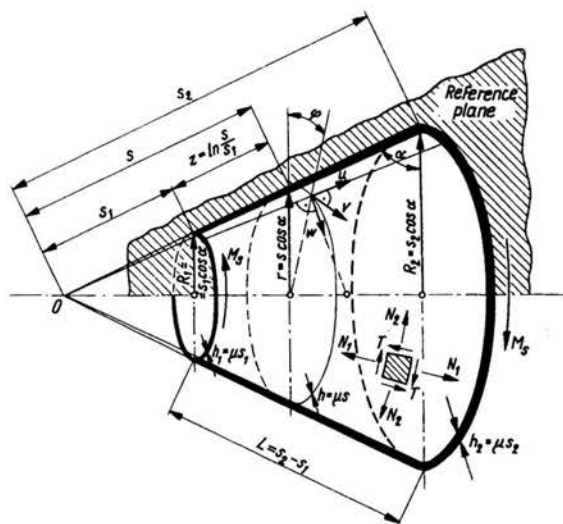

FIG. 1.

- μ coefficient of proportionality characterizing the shell thickness,
- $h = \mu s$ shell thickness at a distance s from the vertex,
- E' Young's modulus along the generators,
- E'' Young's modulus in the circumferential direction,
- ν', ν'' Poisson's ratios, respectively,

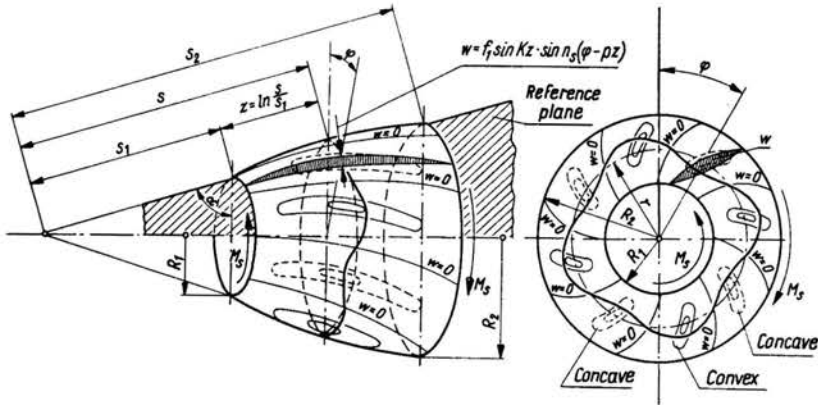

FIG. 2

- M_s torque; $z = \ln(s/s_1)$; n_s number of waves along the periphery; p a parameter characterizing the slope of nodal lines,
- f_1 maximum deflection of the deformed shell,
- $K = \pi / \ln(s_2/s_1)$.

2. Analysis of the deflection surface

Deflection of the shell after buckling is represented by the function

$$(1) \quad w = f_1 \sin(Kz) \sin[n_s(\varphi - pz)].$$

Concavities of the deformed shells form screw-like lines and their maxima occur not at $s = (s_1 + s_2)/2$, but at slightly smaller values of s . This phenomenon is more clearly manifested at increasing values of the ratio s_2/s_1 . The function (1) describes the deflection surface fairly well and satisfies the conditions of simple supporting of the edge approximately.

3. Results of the solution

The problem is solved by a method similar to that used in [1] to yield the number n_s of waves formed along the periphery after buckling of the shell,

$$(2) \quad n_s = 4.02 \left[\sqrt{\frac{E'}{E''} (1 - \nu' \nu'')} \frac{\text{tg } \alpha}{\mu \left(\ln \frac{s_2}{s_1} \right)^2} \right]^{1/4} \cos \alpha$$

and the upper critical torque M_{k0}

$$(3) \quad M_{k0} = 9.17 \frac{E'}{\left[\frac{E'}{E''} (1 - \nu' \nu'') \right]^{5/8}} \frac{(s_1 s_2)^2}{(s_1 + s_2)} \sqrt{\ln \frac{s_2}{s_1}} \sqrt[4]{\mu^9 \sin^3 \alpha \cos^5 \alpha}.$$

The solution applies to such shells in which $1 \leq s_2/s_1 \leq 2$ and $70^\circ \leq \alpha \leq 90^\circ$. In cylindrical and conical shells of constant wall thickness the critical load evaluated from experiments is 15%–20% smaller than the upper critical load. Analogically, it might be expected that the lower critical torque of the shells considered here will also be 15%–20% smaller than the result given by the Eq. (3).

The formulae for n_s and M_{k0} may be reduced to the form

$$(4) \quad n_s \approx \frac{n_{s(h=\mu s_1)}}{\sqrt[4]{2 \frac{R_2}{R_1} / \left(\frac{R_2}{R_1} + 1 \right)}}, \quad M_{k0} \approx \frac{R_2}{R_1} \sqrt[4]{2 \frac{R_2}{R_1} / \left(\frac{R_2}{R_1} + 1 \right)} M_{k0(h=\mu s_1)}.$$

Here, $n_{s(h=\mu s_1)}$ is the number of waves along the periphery, $M_{k0(h=\mu s_1)}$ — the upper critical torque of a conical shell differing from the one considered only by the constant thickness $h = \mu s_1$. From the formulae (4) it becomes evident that variable wall thickness of the shell bears influence on the solution.

References

1. T. GALKIEWICZ, *Problem of stability of an orthotropic conical shell in torsion* [in Polish], *Mechanika Teoretyczna i Stosowana*, **9**, 1, 1971.
2. E. I. GRIGOLYUK, *Elastic stability of orthotropic and layered conical and cylindrical shells* [in Russian], *Analysis of building structures III*, Moscow, 1955.
3. M. KRÓLAK, *Stability of an axially compressed, orthotropic conical shell — a non-linear approach* [in Polish], *Arch. Bud. Maszyn*, **16**, 3, 1969.
4. H. M. MUSHTARI, *Approximate solution of certain problems of stability of a thin-walled conical shell of circular cross-section* [in Russian], *PMM*, **3**, 7, 1943.
5. S. TIMOSHENKO, *Theory of elastic stability*, McGraw-Hill, 1961.
6. A. C. VOLMIR, *Stability of deformable systems* [in Russian], Nauka, Moscow 1967.

TECHNICAL UNIVERSITY OF ŁÓDŹ.

Received December 18, 1974.